



CSS – OD / 107 kWh Grid-tied / Backup Commercial Energy Storage Solution

Model CSS-OU-107 with PCS030B or PCS050B

Quick Installation Guide

Version 1.0

For Europe

Legend

 **WARNING!** This symbol denotes a hazard. It calls attention to a procedure that if not correctly performed or adhered to could result in injury or loss of life. Do not proceed beyond a warning note until the indicated conditions are fully understood and met.

 **CAUTION!** Denotes a hazard. It calls attention to a procedure that, if not correctly performed or adhered to, could result in damage or destruction of the product. Do not proceed beyond a caution sign until the indicated conditions are fully understood and met.

 This symbol indicates that this is the Protective Earth (PE) terminal that must be firmly grounded to ensure the safety of operators.

Safety Instructions

 **WARNING: RISK OF ELECTRIC SHOCK**
DO NOT touch the wires, contacts, terminals, or any conductors connected to the grid circuit inside the equipment.
Failure to follow safety instructions could result in severe injury or death from electric shock.

 **WARNING: LETHAL HIGH VOLTAGES exist inside the product.**

- Note and abide by all warning signs on the product.
- Observe the safety precautions listed in this manual and other related documents.

 **WARNING: Damaged Equipment Hazards**

- Damaged equipment or system failure may cause electric shock or fire!
- Perform an initial visual inspection of the equipment for damage or other hazards before operation.
- Check whether other external devices or circuit connections are secure.
- Confirm that this equipment is in a safe state before operating it.

 **WARNING:** This equipment must be installed by **licensed electrician** and qualified personnel only. The installation and wiring of this equipment must comply with all applicable national, state/provincial, local electrical codes and standards. Attempting installation by unqualified individuals could result in unsafe operation, code violations, personal injury/loss of life, or damage to the equipment.

 **WARNING: Battery Protection**
DC HIGH VOLTAGE! ELECTRIC SHOCK HAZARD!
The battery in the system generates a high voltage when connected. Accidental contact can result in electric shock or life-threatening injuries.

 **WARNING: Ground Fault Safety Warning**
If a ground fault occurs in the Battery Inverter, high voltage may appear on components that are normally not energized. **Accidental contact with these components can cause serious injury or death.**
Before Operating the system

- Check for ground faults: Ensure the system is free of any ground faults.
- Apply protective measures: Implement all required safety precautions before starting operation.

A ground fault can make normally safe parts dangerously live. Always verify system integrity and follow safety protocols to protect yourself and others.

 **WARNING: Live Line Measurement**

- There are high voltages in the equipment in the integrated Battery Inverter, and accidental touch may cause fatal electric shock hazards.
- During live measurement, take appropriate protection, such as wearing insulating gloves.
- There must be an accompanying person to ensure personal safety.

 **WARNING: Improper parameter settings**

- Improper parameter settings may affect the normal function realization of internal devices.
- Only authorized professionals can set the parameters.

 **WARNING: Regulatory Compliance**
The installation and various operations of the integrated PCS must comply with the relevant standards and regulations of the country/region where the project is located.

 **WARNING:** The inverter should not be directly connected to life support equipment or medical equipment.

Personal Protective Equipment



Safety Rubber Shoes



Helmet



Rubber Gloves



Safety Clothing



Goggles

Required tools for Battery Cabinet 107 kWh & Battery Inverter

 **WARNING!** Use only insulated tools



Torque wrench with 7mm, 10mm, 16mm, 17mm, 18mm, 19mm sockets



Wire Cutter



Crimping tool



Phillips screwdriver M4, M6, M10 L= 230 mm



Heat gun



Multimeter ($\geq 1000 V_{DC}$)



Cable Stripper



Wire Stripper



Drill ($\varnothing 10$ mm drill)



Box Cutter



Pipe Cutter



Ladder



Rubber Hammer



Slotted Screwdriver (10 mm slot)



Slotted Screwdriver for Terminal Block Screws (2 mm slot)



Adjustable Wrench



Open-end torque wrench

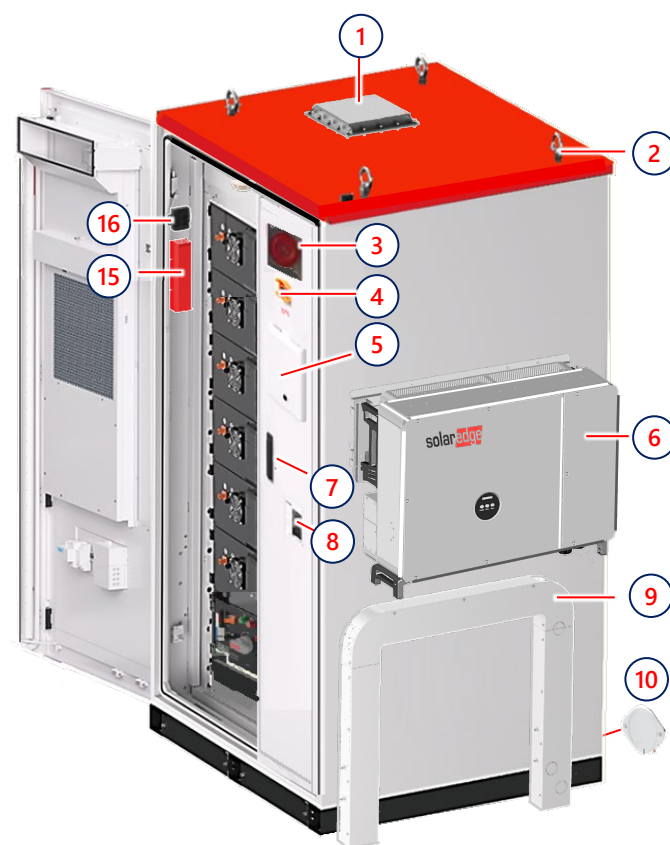
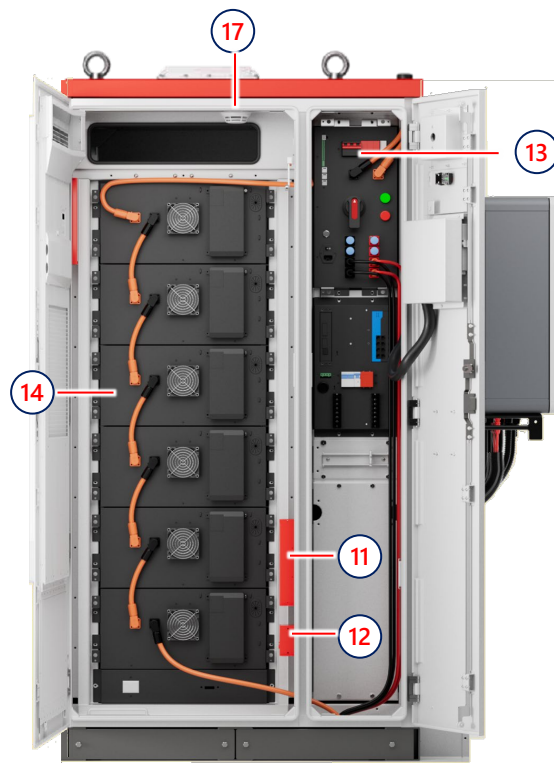

- 1. Explosion Relief Panel
- 2. Four Eye Bolts
- 3. Acoustic-Visual Alarm
- 4. Emergency Power Off (EPO) Switch
- 5. CSS Local Interface Display (EMS)
- 6. Battery Inverter
- 7. Door Lock

- 8. Nameplate
- 9. Wiring Duct
- 10. Intake Valve (on back side of cabinet)
- 11. Aerosol Fire Extinguisher 1
- 12. Fire Suppression Control Box
- 13. Energy Modules Management Unit
- 14. Energy Module (x6)
- 15. Aerosol Fire Extinguisher 2

- 16. CO Detector
- 17. Smoke Detector
- 18. DM65 Fire Fighting Valve
- 19. Wiring Duct (optional)
- 20. Heating, Ventilation, and Air Conditioning (HVAC)
- 21. Exhaust Valve

Battery Cabinet 107 kWh



1435 KG

Battery Inverter 30/50 kW

*Without a mounting bracket

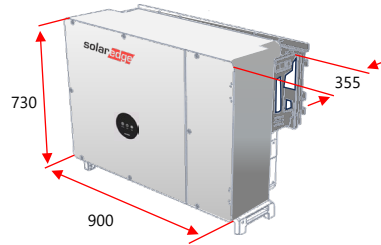

80 KG

Battery Inverter 30/50 kW Battery Cabinet 107 kWh

*Assembled dimensions with mounting a bracket



1515 KG

All dimensions are in [mm]

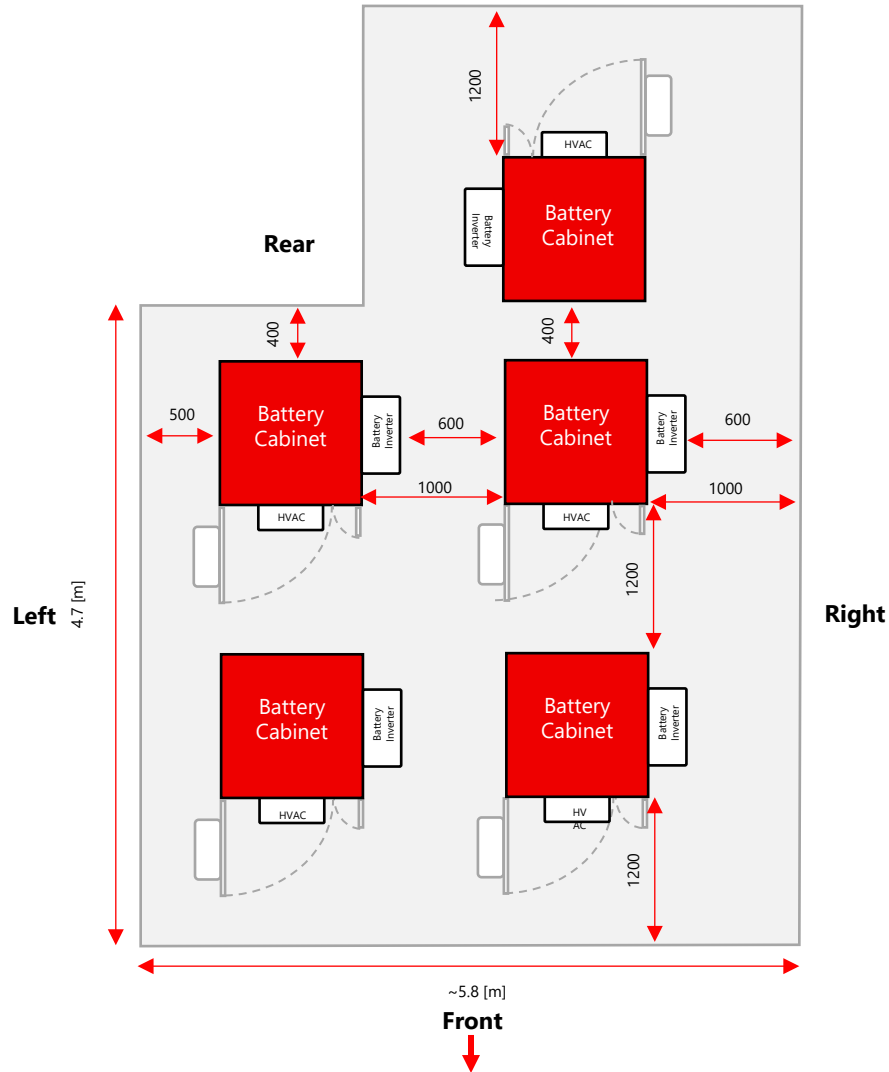

Default Layout & Clearance Distances (Top & front view)

All dimensions w/o units are in [mm]

⚠ WARNING! To avoid flood damage and safety hazards, the cabinet must be installed on a concrete platform with a minimum height of 300 mm.



Above ground: Minimum 300

Below ground: Minimum 400

NOTES!

- Local codes and regulations could extend the required clearances beyond what is specified in this manual
- Before proceeding with installation, consult with relevant authorities to ensure compliance with local regulations concerning clearance distances.

CAUTION

1. The installation, use, and operation of outdoor equipment and cables, including but not limited to the movement of equipment, operation of devices and cables, connection or disconnection of signal interfaces exposed to outdoor conditions, and work at heights. Outdoor installations are strictly prohibited during severe weather conditions such as lightning, rain, snow, or high winds.
2. Avoid installing the equipment near underground facilities like underwater pipes and air outlets or in places prone to condensation. Additionally, steer clear of areas susceptible to water leakage, such as around air-conditioning outlets, vents, and outlet windows in the machine room. This will help prevent liquids from entering the equipment and causing malfunctions or short circuits.
3. Avoid installing the equipment in areas with poor geological conditions, such as rubbery or weak soil, waterlogged ground, or regions susceptible to land subsidence. When installing in a sandy environment, increase the frequency of routine maintenance for the battery vent and HVAC systems: perform a visual inspection weekly and clean as needed based on observed conditions.
4. Do not place the equipment or operate it in a flammable environment or an environment that contains explosive gas or smoke.
5. Avoid installing the battery cabinet in sandy environments.
6. Avoid installing the battery cabinet on unstable or vibrating foundations.
7. Do not install the battery cabinet in a working environment with metal conductive dust.
8. When the equipment is running, do not cover the vents or heat dissipation system to prevent fire due to high temperature.



CAUTION! For indoor installations ventilated room is required.



CAUTION! CSS – OD solution must be installed: >2km from the sea, when installed in an outdoor location, or >1km when installed in indoor locations.



NOTE Battery Cabinet & Battery Inverter max noise is <65 dBA @ 1 meter distance.



CAUTION! When Installed in indoor locations consider heat dissipation values of all installed devices when choosing appropriate room / space for their installation.

| Battery Cabinet | |
|------------------|-------------------------|
| Max Power | Heat Dissipation |
| 50 kW | ~0.87 kW (2970 BTU/h) |
| 30 kW | ~0.87 kW (2970 BTU/h) |
| Battery Inverter | |
| Max Power | Heat Dissipation |
| 50 kW | ~1.35 kW (4606.2 BTU/h) |
| 30 kW | ~0.75 kW (2559 BTU/h) |



IMPORTANT NOTE!

1. Communication cables and power wires **must** be laid separately (DC and AC loops).
2. The distance between control/communication and power cables must be greater than 300mm.
3. In cases when control cables cross power cables, validate that the angle between the two cables is kept at 90°.
4. The recommended minimum distance between parallel shielded data cables and power cables is shown below:

| Parallel length (m) | Min space distance (m) |
|---------------------|------------------------|
| 200 | 0.15 |
| 300 | 0.5 |
| 500 | 1.2 |

IMPORTANT NOTE: The battery cabinet requires an active internet connection for commissioning and monitoring. Before installing the battery cabinet, verify that the **Internet service is reliable**. Do not connect the battery until connectivity is confirmed. Failure to do so may result in commissioning failure, loss of monitoring, missed alerts, or warranty issues.

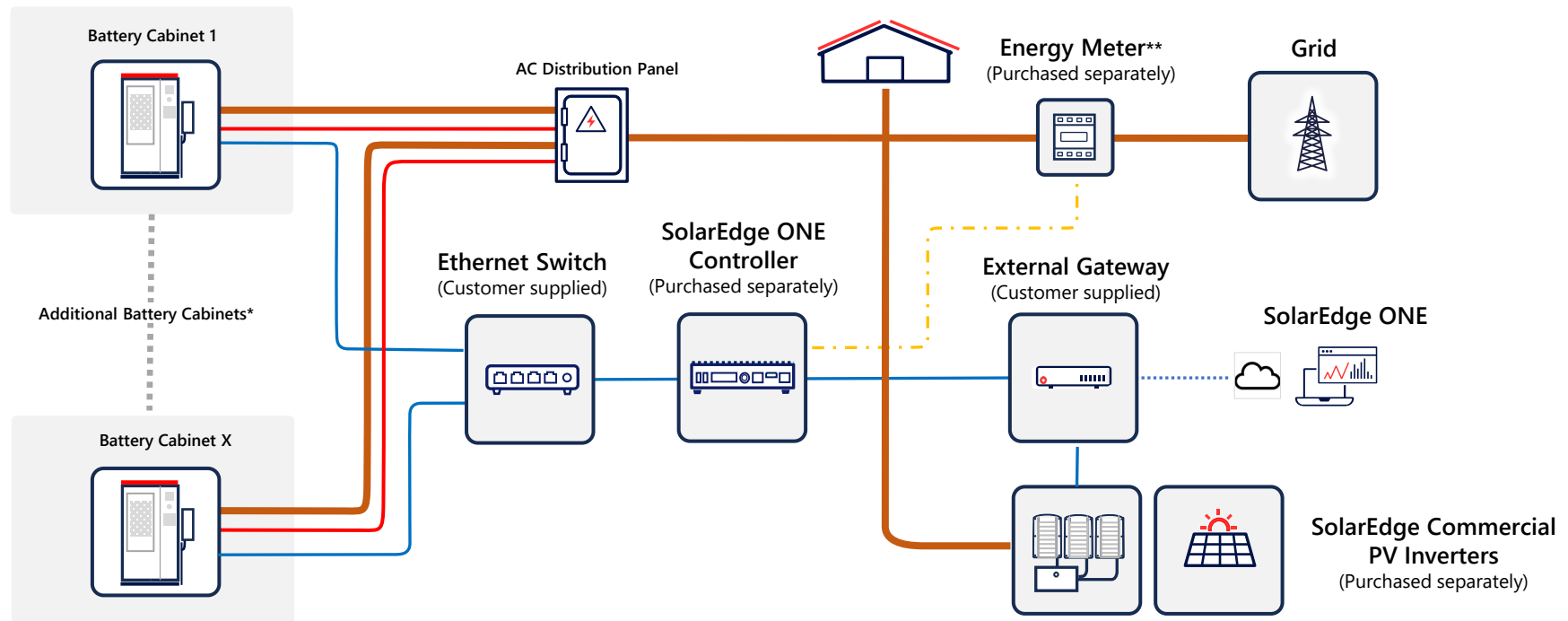

- Three Phase AC Cable
- Single Phase AC Cable for HVAC (not provided)
- Modbus TCP Communication Cable (LAN)
- - - RS485 Comm. Cable (not provided)

* Up to 20 Battery Cabinets support.
 ** Use the SolarEdge SE-MTR-3Y-400V-A Energy Meter or an approved meter.

NOTES:

- Keep in upright position 
- Before opening, validate package integrity



IMPORTANT: Do not open damaged packages.
Contact SolarEdge to review the case.

NOTE: For SolarEdge commercial Battery storage and transportation guidelines refer to:
<https://knowledge-center.solaredge.com/sites/kc/files/se-commercial-battery-storage-transportation-and-storage-guideline-90kwh-eng.pdf>

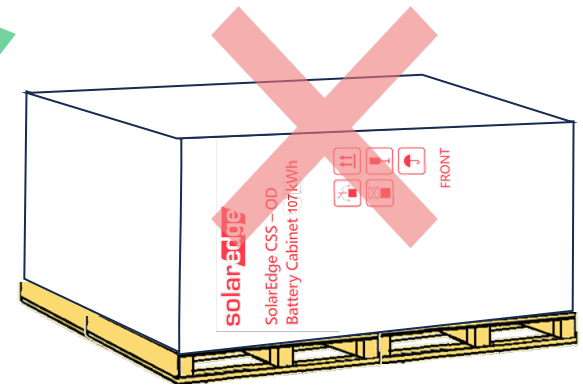
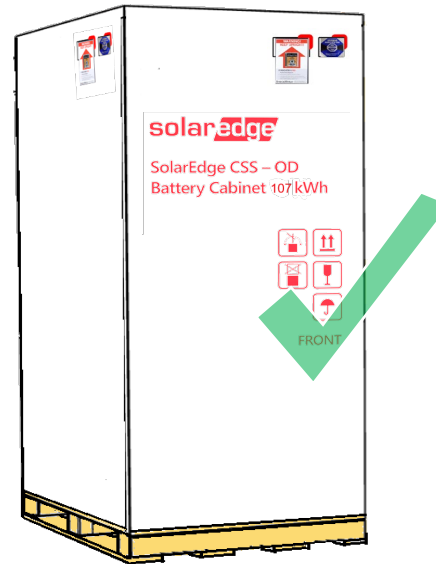
**NOTES: For Battery Cabinet Package**

- Verify that the shock and tilt label sensors, on the front and right sides of the package, show green indication.
- When opening package, check the integrity of the fire safety solution. If aerosol gas was ejected due to any fault occurred during transportation the battery cabinet shall be replaced.
- If one of the sensors is red, please contact SolarEdge and do not open the package.



Transporting Battery Cabinet with the Wooden Box

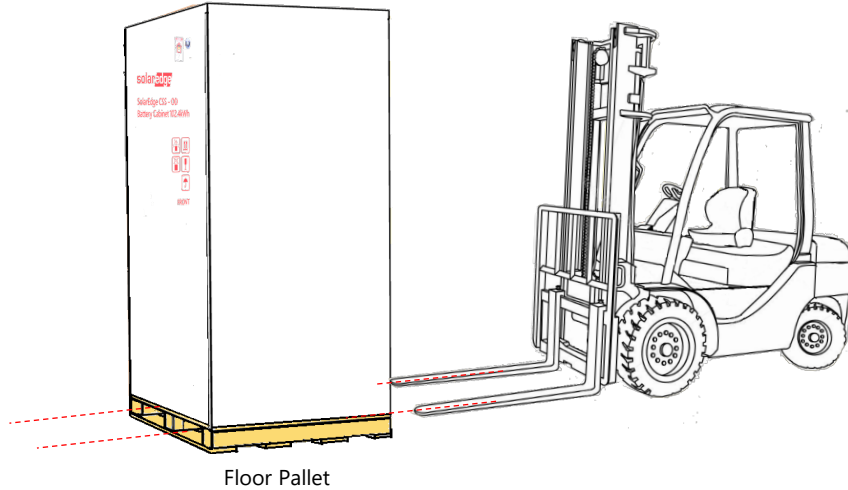

Transporting Battery Cabinet Standalone

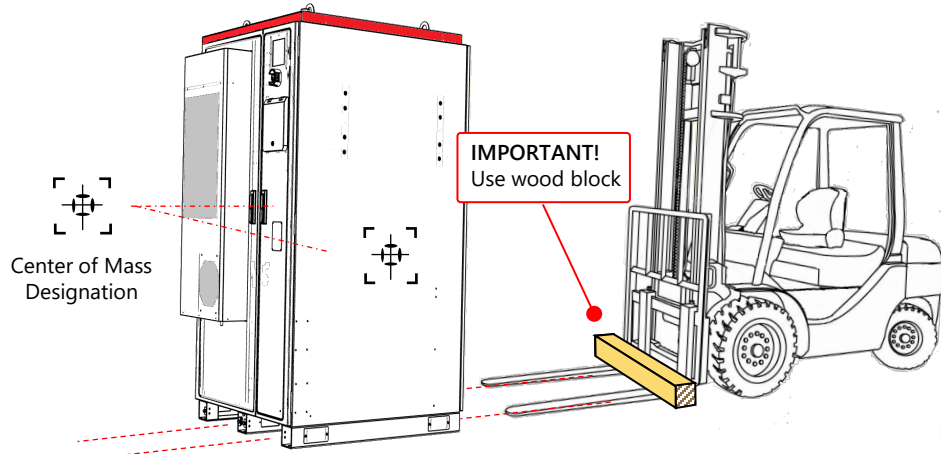

Forklift Requirements

WARNING! The forklift must be able to lift at least 3 tons in carrying capacity

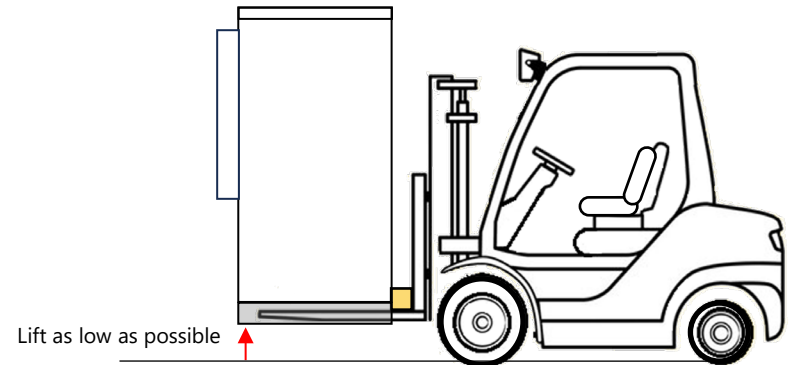
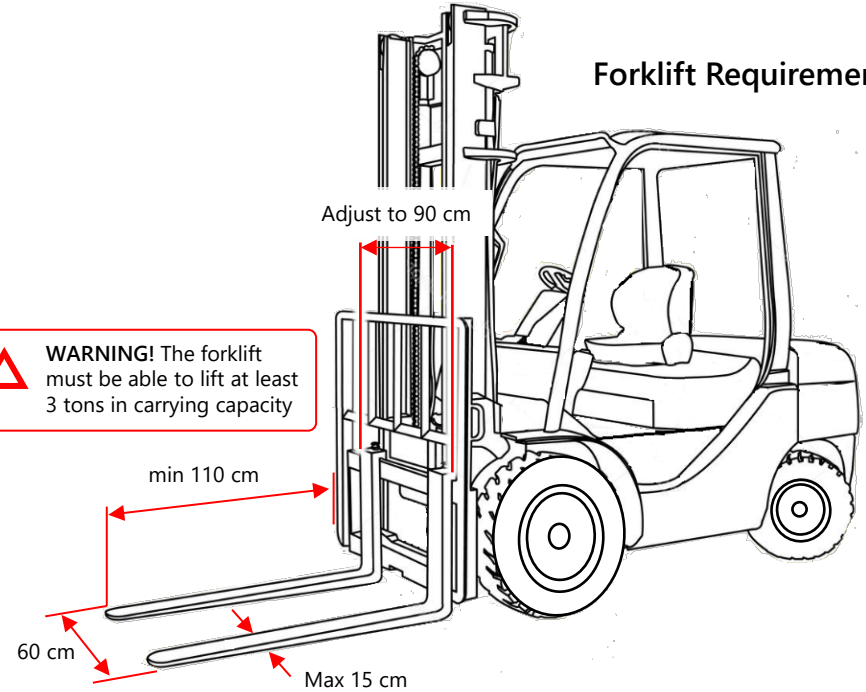

HOISTING REQUIREMENTS

WARNING!

1. A trained and qualified lifting personnel is required.
2. Do not operate a hoist if severe weather or wind is apparent when conducting hoisting outdoors.
3. Keep unauthorized people from entering the area and standing under crane boom.
4. Ensure that the crane and slings meet the load-bearing requirements.
5. To prevent the cabinet from scratching, do not drag it when installing and removing hoisting equipment.
6. Check to ensure that the hoisting tools are in good condition.
7. Ensure that all the doors of the equipment are closed and locked during transportation.

Standalone Battery Cabinet Crane Transportation



WARNING! Do not tilt the cabinets during transportation.

Packaged Battery Cabinet Crane Transportation

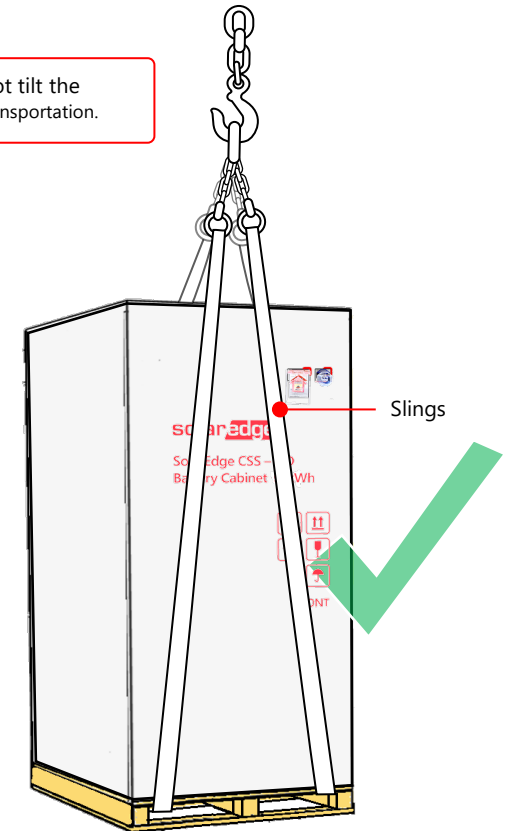



NOTE: Disassembly of wooden box must start from the top side

1 Top

Rear

5

NOTE: Leave protective nylon covering in this area

Left

3

NOTE: Use flat head screwdriver to unfold the connecting buckles

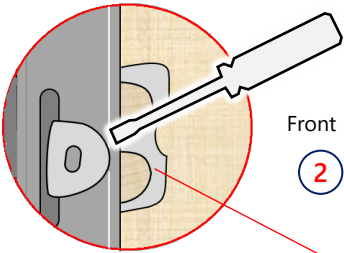

Front

2

solar**edge**
SolarEdge CSS - OD
Battery Cabinet 90kWh



FRONT

Right

4

Battery Cabinet Package

8

NOTE: Remove the screws and nuts securing the cabinet to the pallet using 19 mm socket (x6)

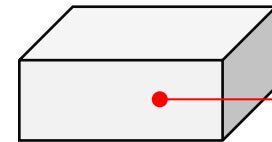

Battery Inverter Package

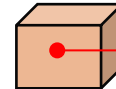

Cabling Package
(See section Part Kits 4-5 for the correct box)

7

Mounting Battery Cabinet on Concrete Base Platform

Option 1: Unified Concrete Platform Base with Embedded Steel Plate with Studs

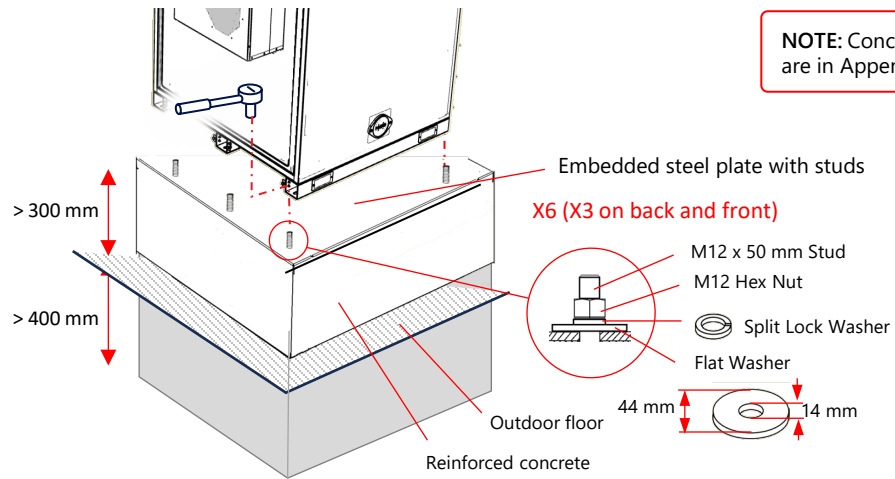

NOTE: Bolts, nuts, and washers are not supplied. Torque depends on the mounting pad. For concrete pads use 60 Nm.

NOTE: Concrete pad guidelines are in Appendix B

Option 3: Unified Concrete Platform Base with Drilling Occurs on Site

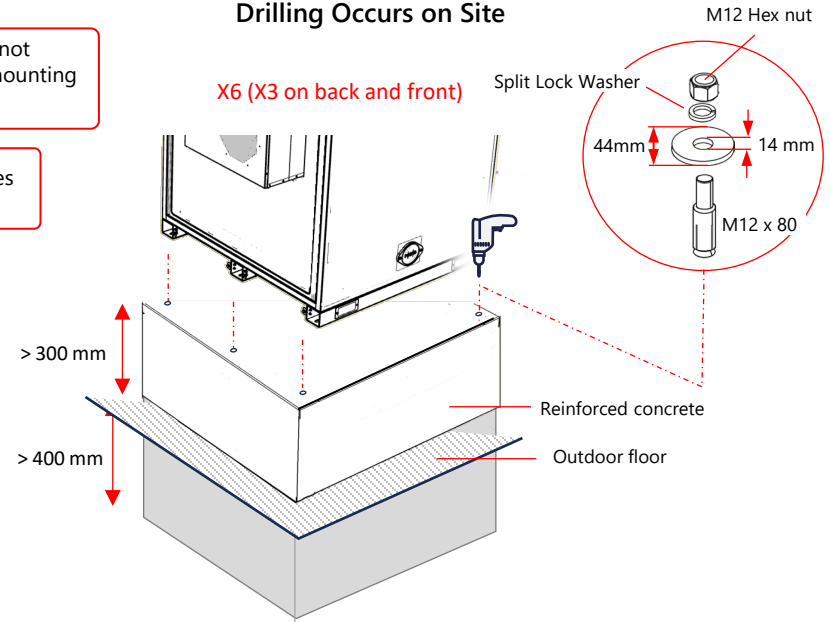

Option 2: Hollow Concrete Platform Base with Embedded Steel Plate with Studs

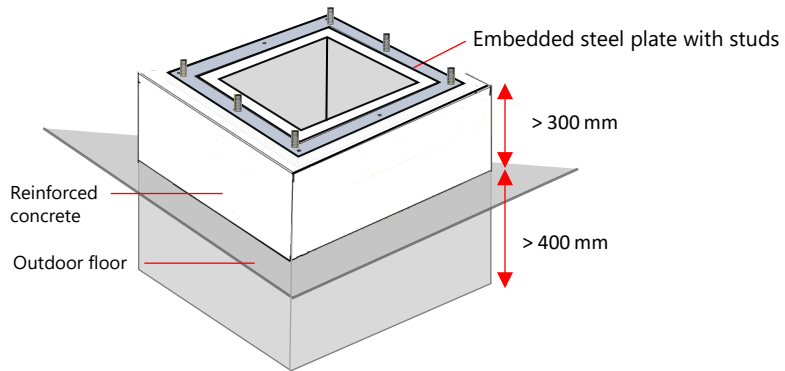

Option 4: Hollow Concrete Platform Base with Drilling Occurs on Site

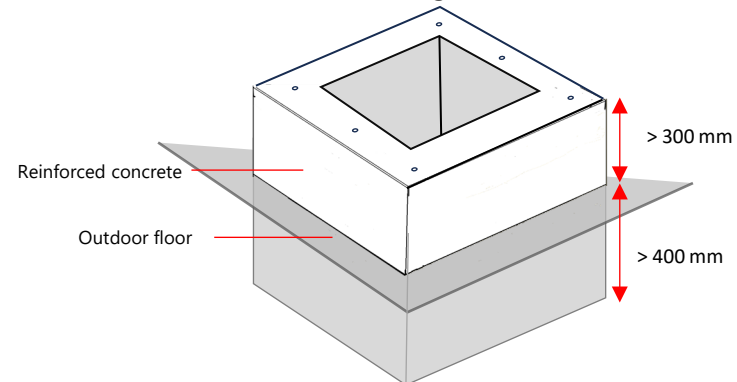

Battery Cabinet Package Contents (Inside Accessories Box)



PAY ATTENTION!
All Cables are marked
with a designation label

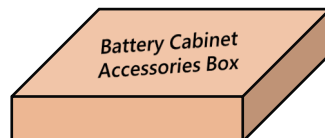

Forklift Slots Covers (x4) (Y)
(Outside Accessories Box)

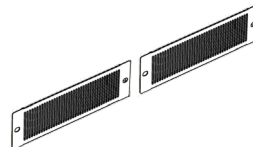

**Battery Cabinet
Wiring Duct (G)**

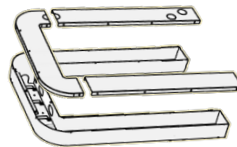

PE cable (0.7m) (E)



Battery Cabinet Package Contents (Inside Battery Cabinet)

Sealant (x4) (H)

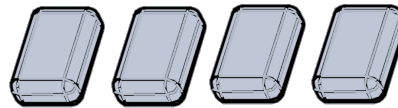

Corrugated Plastic
Conduit \varnothing 34.5 mm (I)



Corrugated Plastic
Conduit \varnothing 21 mm (J)



Battery Inverter Package Contents

Battery Inverter
Mounting Bracket kit (K)

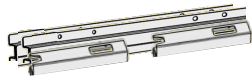

Battery Inverter

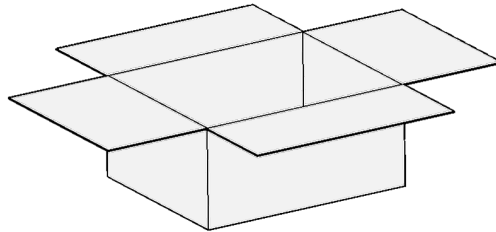
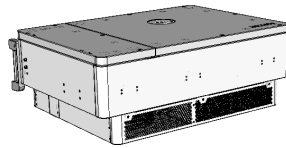

Bracket M10 Mounting
Bolts (x12 - 8 on
cabinet wall) (Q)

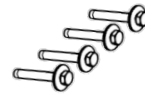

Bracket Lock
M6 Bolts
(x2) (R)



Bracket
Assembly Bolts
(x4) (P)



Right-angled Trox
Star Allen key



M6 Lugs (x15) (S)



Cables Shrinks
(x15) (T)

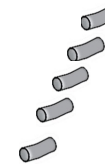

NOTE: These lugs are compatible with class 2 wires. Please ensure you provide your own lugs if class 5 or 6 wires are used on site.

Cabling Package Contents

Battery Cabinet to Battery Inverter DC Cables (3m) (B)

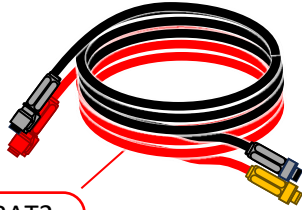

BAT2

Battery Cabinet to Battery Inverter DC Cables (3m) (A)

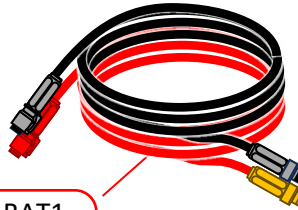

BAT1

Battery Cabinet to Battery Inverter COM cable (3.5m) (C)

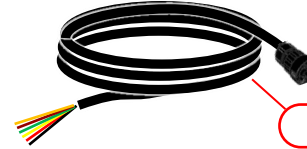

PCS-COM

PAY ATTENTION!
All Cables are marked with a designation label

PCS-PARA1/2 Cable



NOTE: THIS PROVIDED CABLE SHOULD NOT BE USED

DO NOT USE!

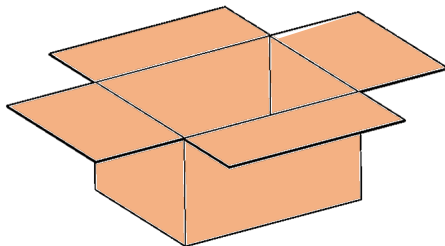

Mounting Battery Inverter onto the Battery Cabinet

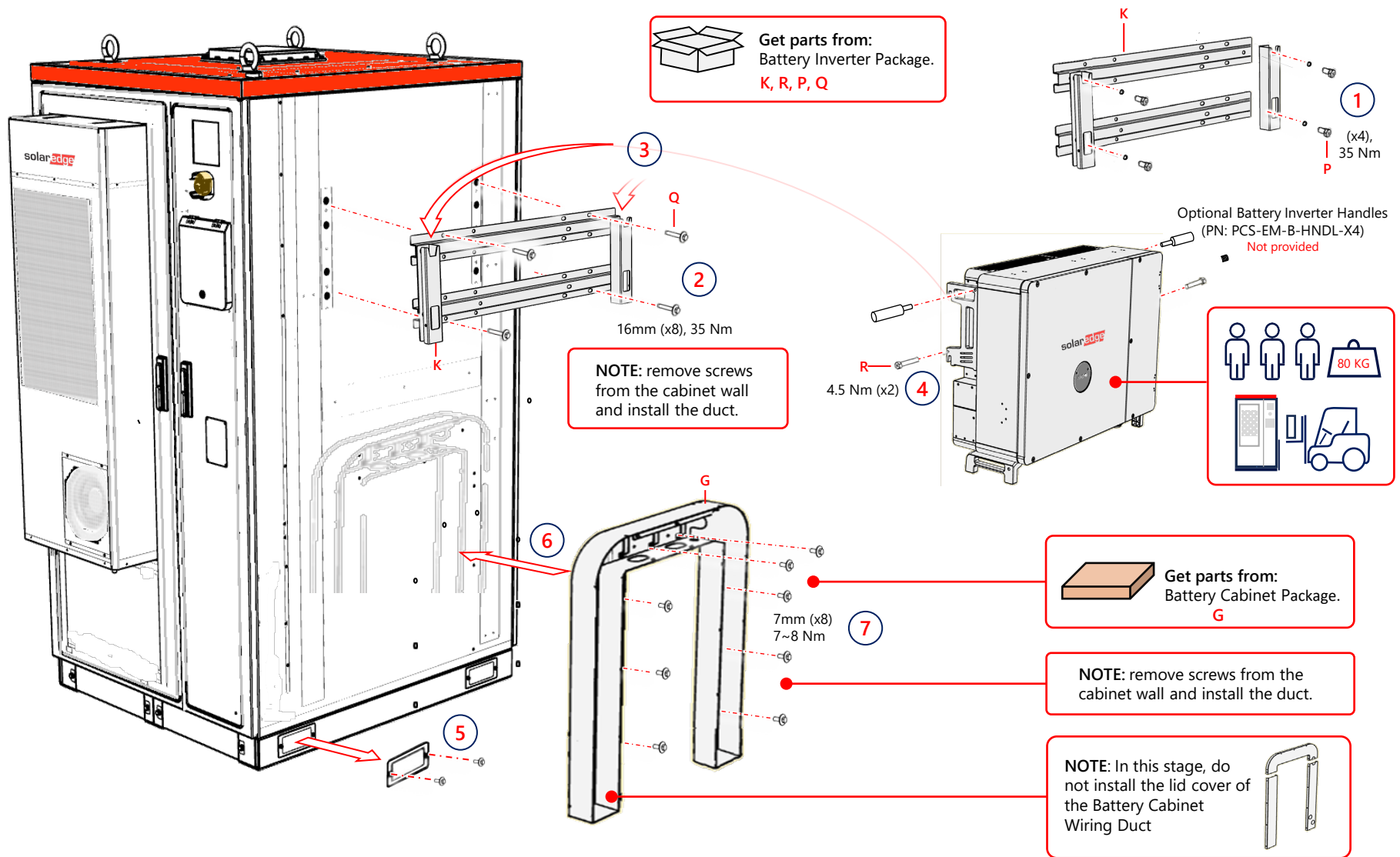

Battery Cabinet & Battery Inverter PE Wiring

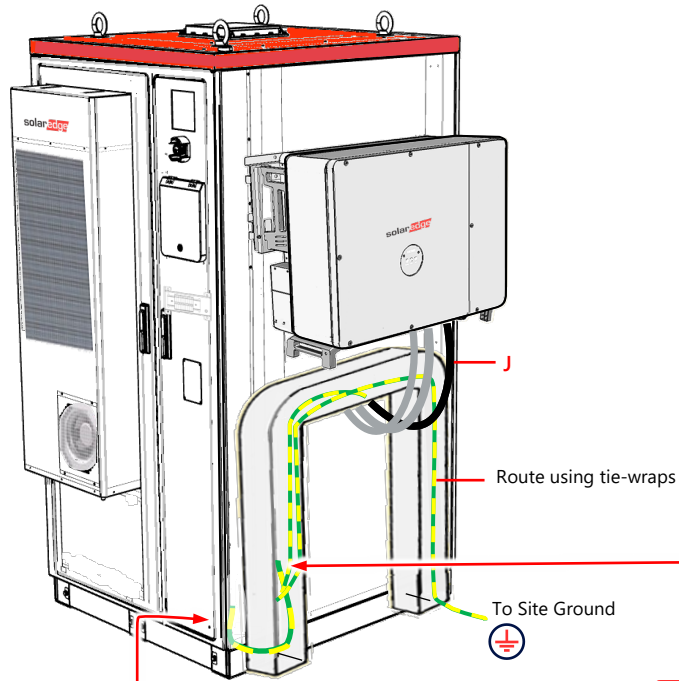

Battery Inverter

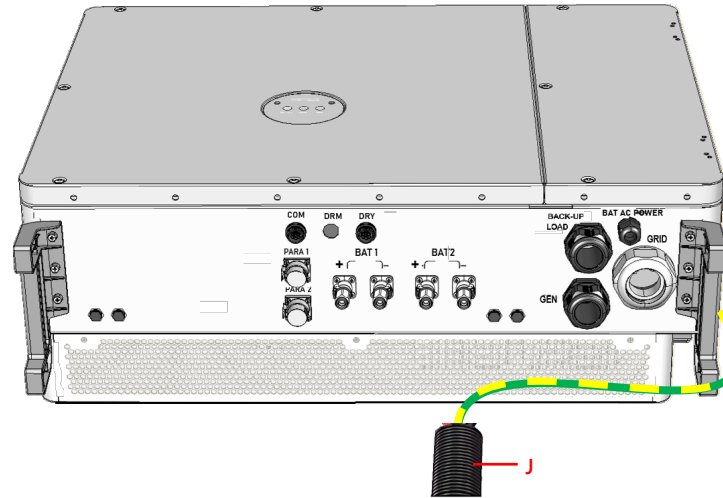

Get part from:
Battery Inverter
Package
E

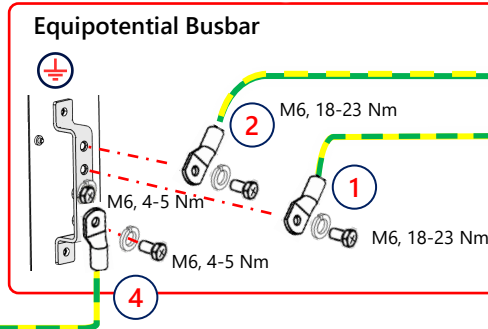
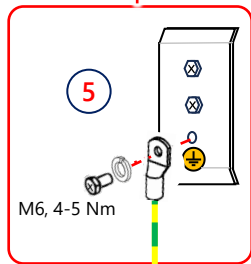
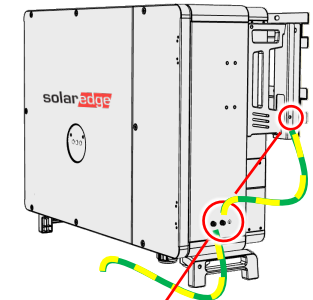

NOTE: Cut the corrugated tubes to the required length.

25 mm², M6 lug
(Not supplied)

Site Ground

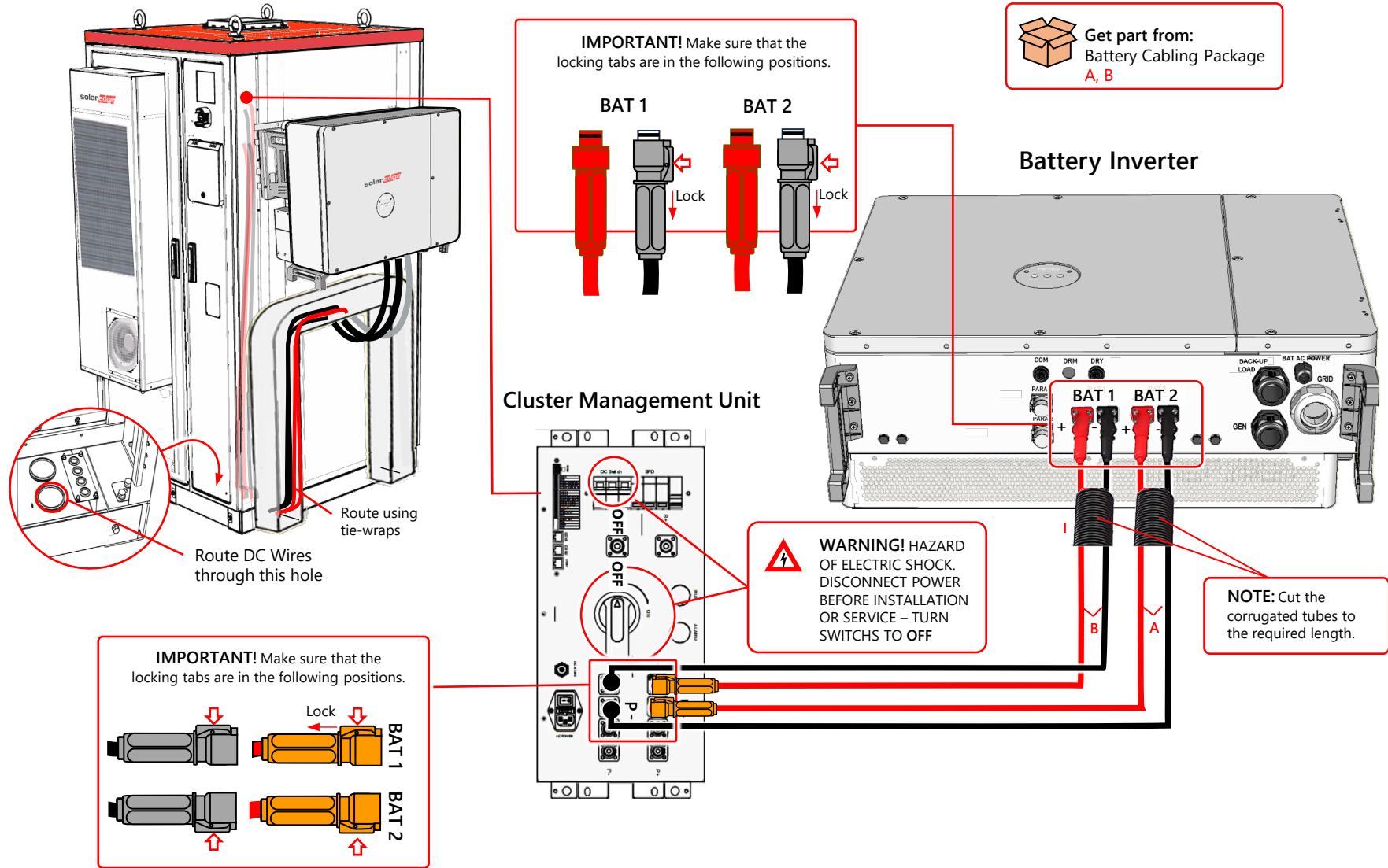

IMPORTANT! Make sure that the locking tabs are in the following positions.

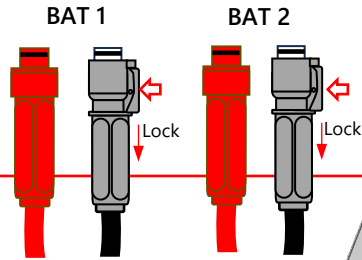

Get part from:
Battery Cabling Package
A, B

Battery Inverter

Cluster Management Unit

WARNING! HAZARD OF ELECTRIC SHOCK. DISCONNECT POWER BEFORE INSTALLATION OR SERVICE - TURN SWITCHES TO OFF

NOTE: Cut the corrugated tubes to the required length.

IMPORTANT! Make sure that the locking tabs are in the following positions.

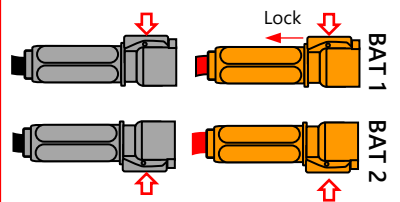

Route DC Wires through this hole
Route using tie-wraps

Battery Inverter

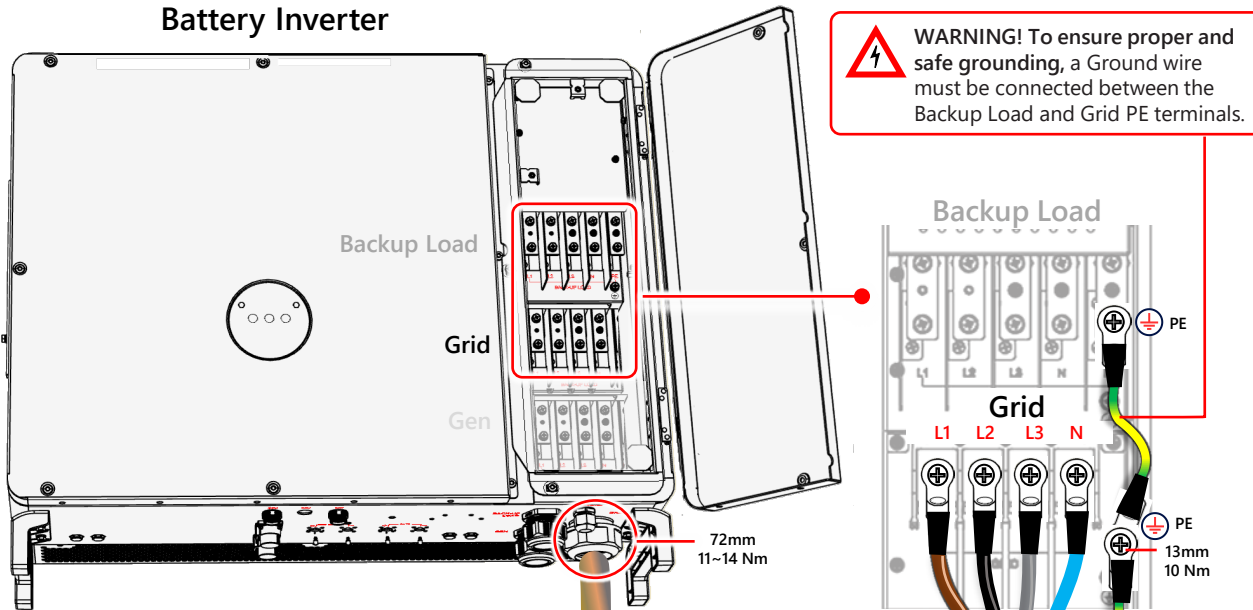

⚠ WARNING! To ensure proper and safe grounding, a Ground wire must be connected between the Backup Load and Grid PE terminals.

IMPORTANT! It is the installer's responsibility for the installation to comply with all local regulations, standards (wiring, safety etc.)

NOTE: Cable properties: (Not supplied)

- Multi-stranded class 5 or 6 flexible **copper** conductors
- 35mm² cross-section wires cable.
- Grid Cable maximum current is 144A for PCS 050B
- And 87A for PCS 030B (per phase)
- Crimp M6 lugs provided. Lugs fit class 2 cables.
- For class 5 or 6, bring your lugs.
- To keep the gland sealed, use 5C or 4C cable type. (3ph+N+PE)

⚠ WARNING! Connect the ground wires in accordance with local regulations.

NOTES:

1. Recommended Grid circuit breaker parameters: 3P 200A/400VAC. If required by local regulation, use type A, 300 mA RCD.

⚠ WARNING! When the Inverter runs in a TN-C-S system:

- The neutral (N) and protective earth (PE) must be separated before connecting to the backup Inverter and the backed-up loads.
- This separation is done at the main distribution point, where the system transitions from TN-C-S to TN-S.
- After this point, no additional neutral-to-ground connections are allowed.

PCS 030B Cross-section: 20~35mm²
 PCS 050B Cross-section: 35~50mm²

NOTE: Strip ≤240mm of the cable jacket

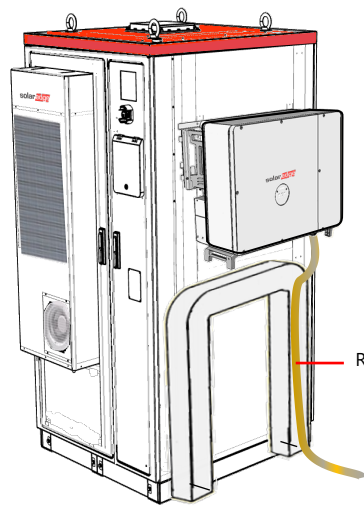
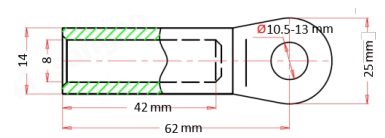

AC Distribution Panel
 (Infrastructural preparation of the client, not supplied by SolarEdge)

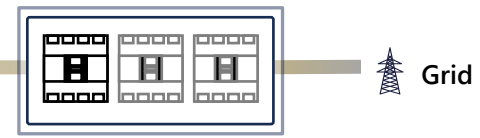

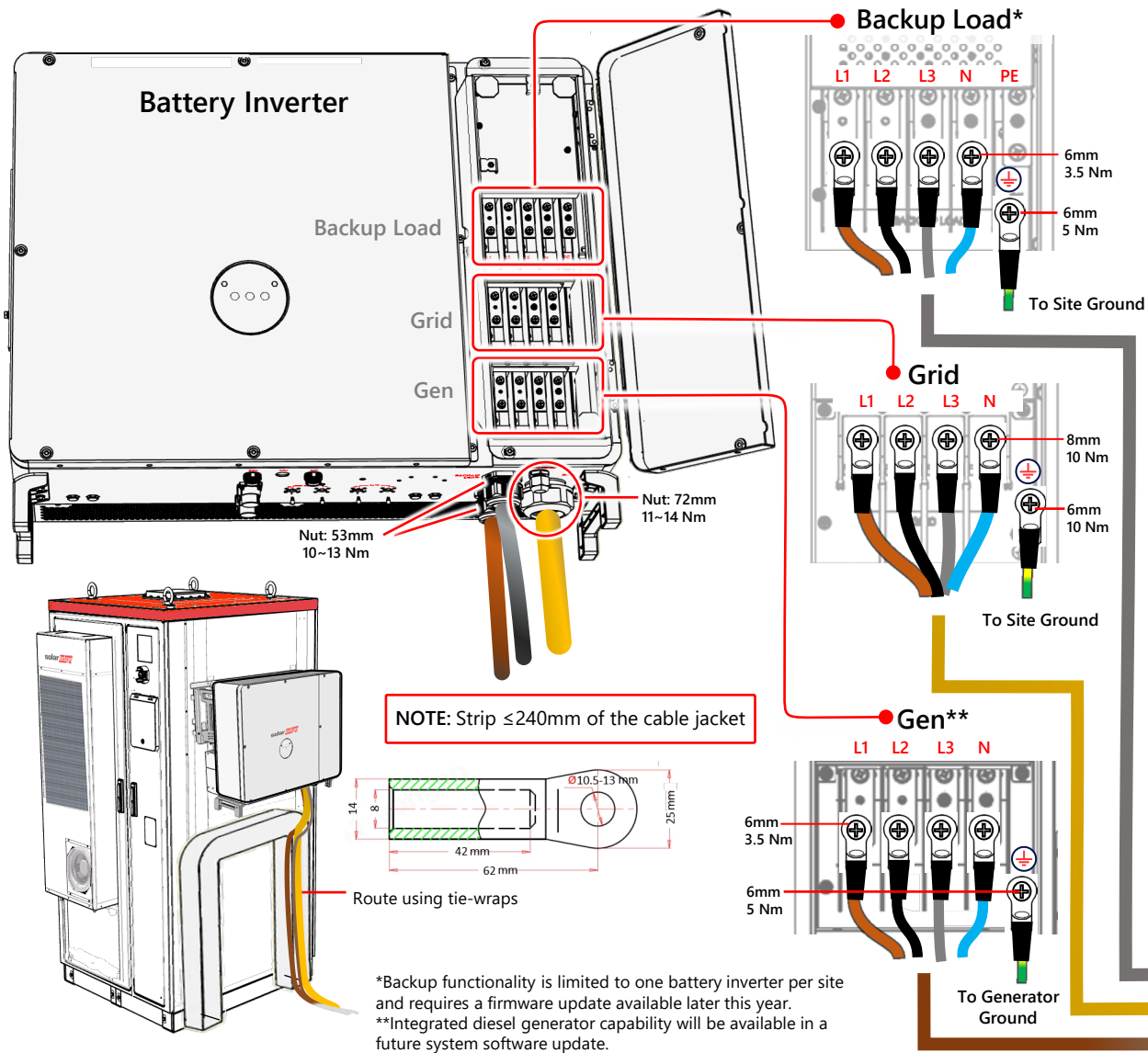

| Cable Type | Max Current (per phase) | Wire Cross-section (mm ²) | Proposed Diameter (AWG) |
|-------------|-------------------------|---------------------------------------|-------------------------|
| Grid | 87A (PCS 030B) | 20~35 mm ² | 2~4 AWG |
| | 144A (PCS 050B) | 35~50 mm ² | 2 AWG |
| Backup Load | 110A | 16~20 mm ² | 4~6 AWG |
| Generator | 110A | 16~20 mm ² | 4~6 AWG |
| Ground | | <16 mm ² | 5~6 AWG |

NOTE: Cable properties: (Not supplied)

- Multi-stranded class 5 or 6 flexible **copper** conductors
- Crimp M6/M8 lugs provided. Lugs fit class 2 cables. For class 5 or 6, bring your lugs.
- To keep the gland sealed, use 5C or 4C cable type. (3ph+N+PE)

⚠ WARNING! Connect the ground cables in accordance with local regulations.

NOTE:

- Recommended Grid circuit breaker parameters: 3P 200A/400VAC. If required by local regulation, use type A, 300 mA RCD
- Recommended Backup* Load and Diesel Generator** circuit breaker parameters: $\geq 125A/\geq 400VAC$

⚠ WARNING! When the Inverter runs in a TN-C-S system:

- The neutral (N) and protective earth (PE) must be separated before connecting to the backup* Inverter and the backed-up loads.
- This separation is done at the main distribution point, where the system transitions from TN-C-S to TN-S.
- After this point, no additional neutral-to-ground connections are allowed.

AC Distribution Panel
(Infrastructural preparation of the client, not supplied by SolarEdge)

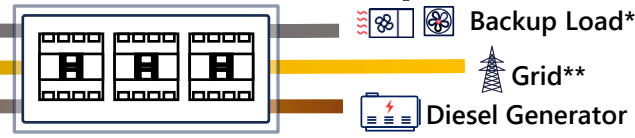

*Backup functionality is limited to one battery inverter per site and requires a firmware update available later this year.
**Integrated diesel generator capability will be available in a future system software update.

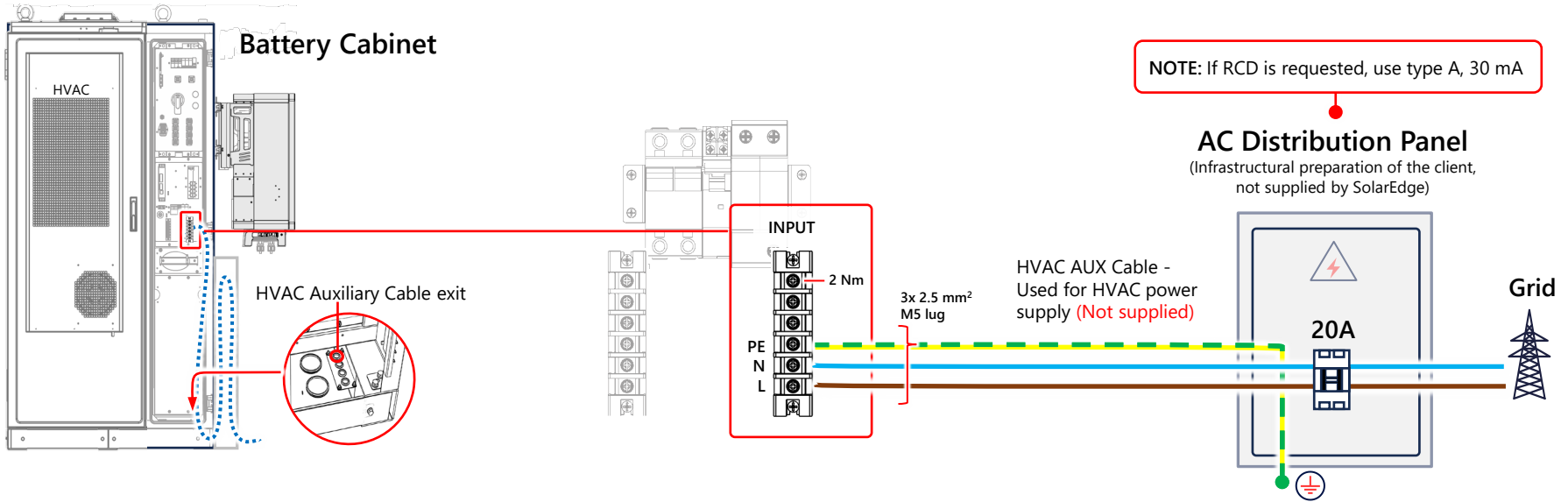

Battery Cabinet with Backup*

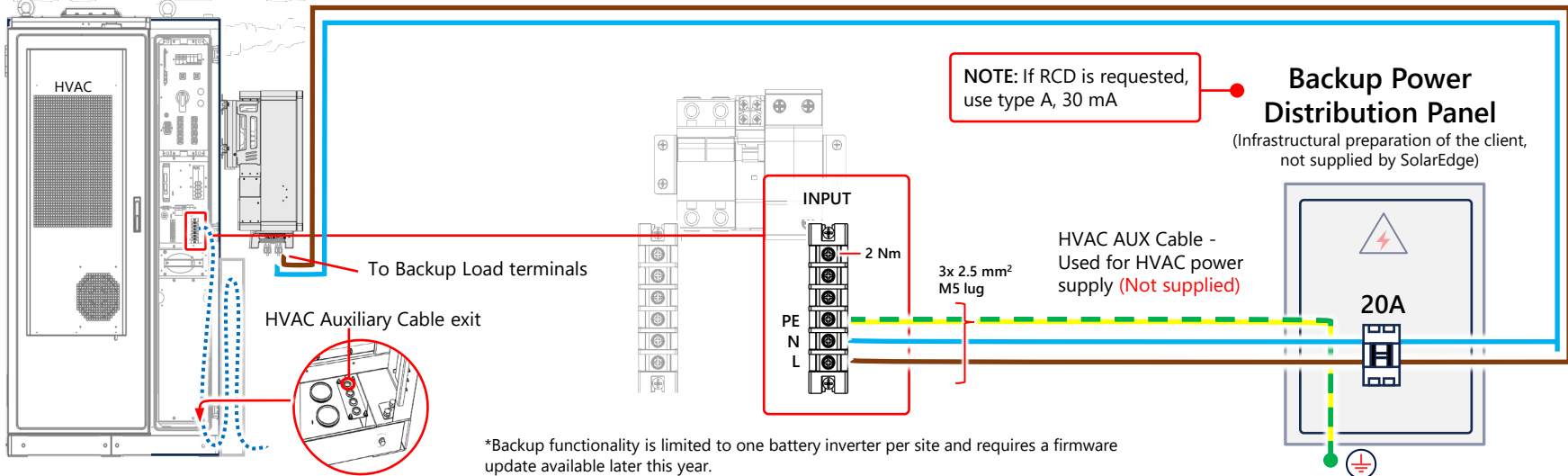

*Backup functionality is limited to one battery inverter per site and requires a firmware update available later this year.

Wiring Communication between Battery Cabinet & Battery Inverter

COM Connector Wiring

- Pin 2 REMS PCS 485 - A2: Brown
 - Pin 1 EMS PCS 485 - A1: Black
 - Pin 6 EMS PCS CANL: Red
 - Pin 5 EMS PCS CANH: Light Brown
 - Pin 3 MBMU PCS CANH: Green
 - Pin 4 MBMU PCS CANL: Yellow
- Screws torque: 0.2 Nm

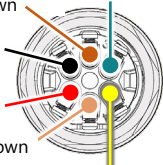

Battery Inverter

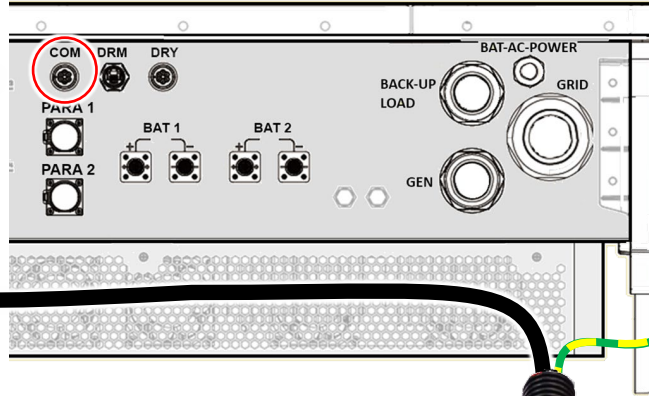

Get part from:
Battery Cabling Package C

Battery Cabinet

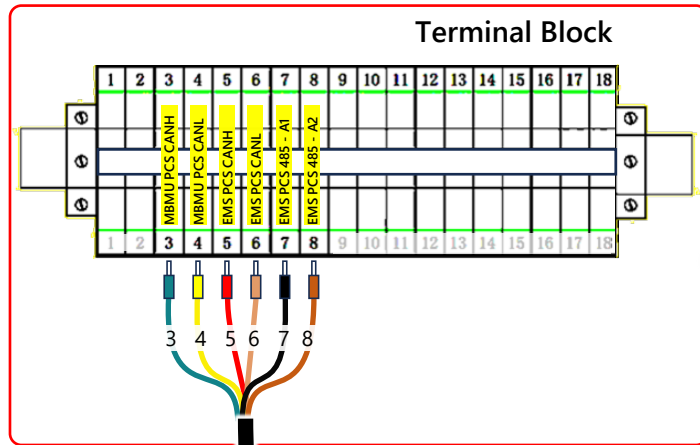
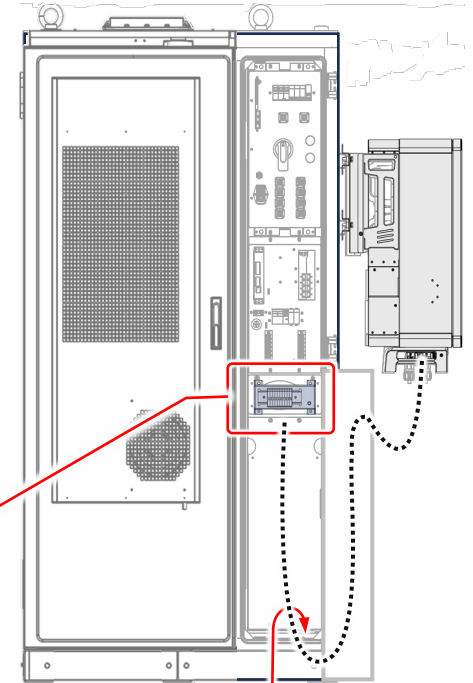

PCS-COM Cable

Wiring Communication Between Battery Cabinet & Diesel Generator*

DRY Connector Wiring

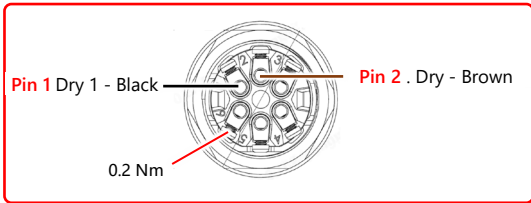

Battery Inverter

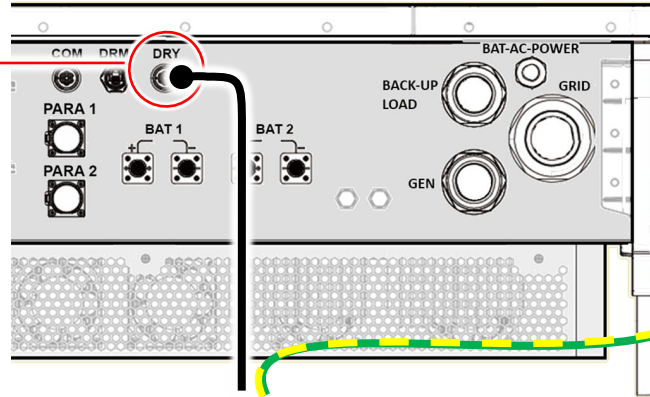

 Get parts from:
Battery Cabinet Package C and D

Battery Cabinet

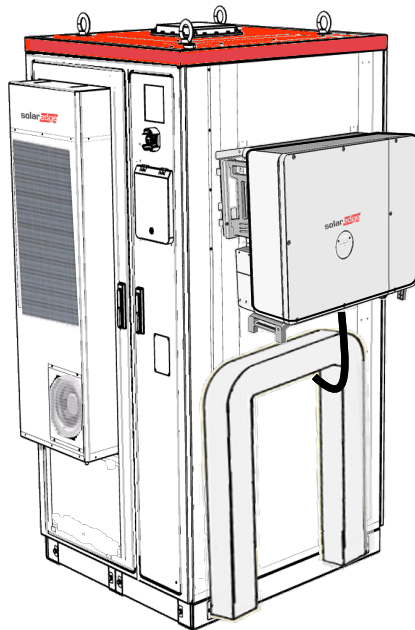

DRY Contact Communication Cable

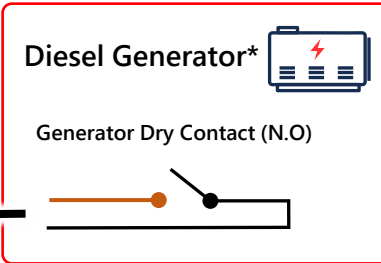

*Integrated diesel generator capability will be available in a future system software update

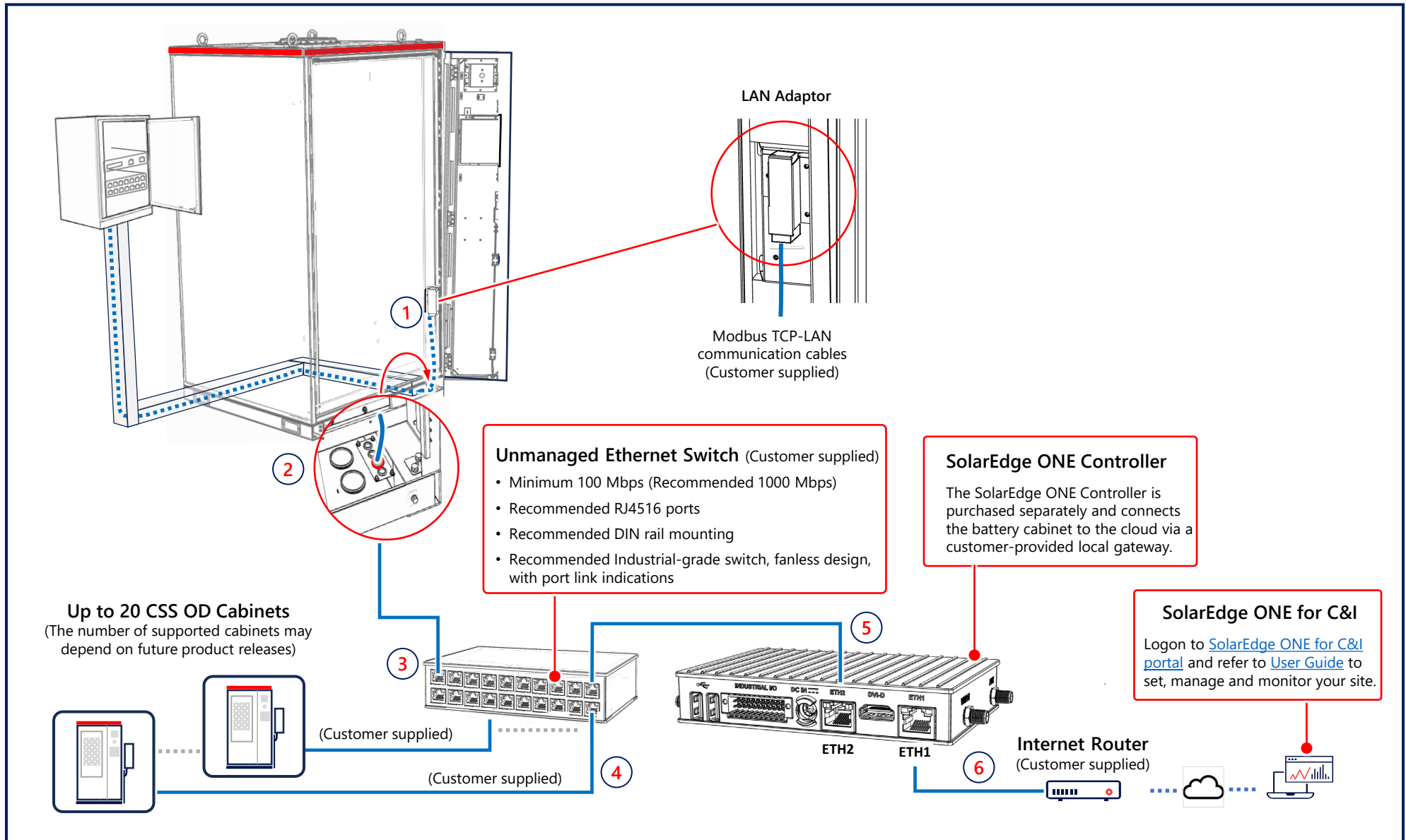

Connecting Energy Meter

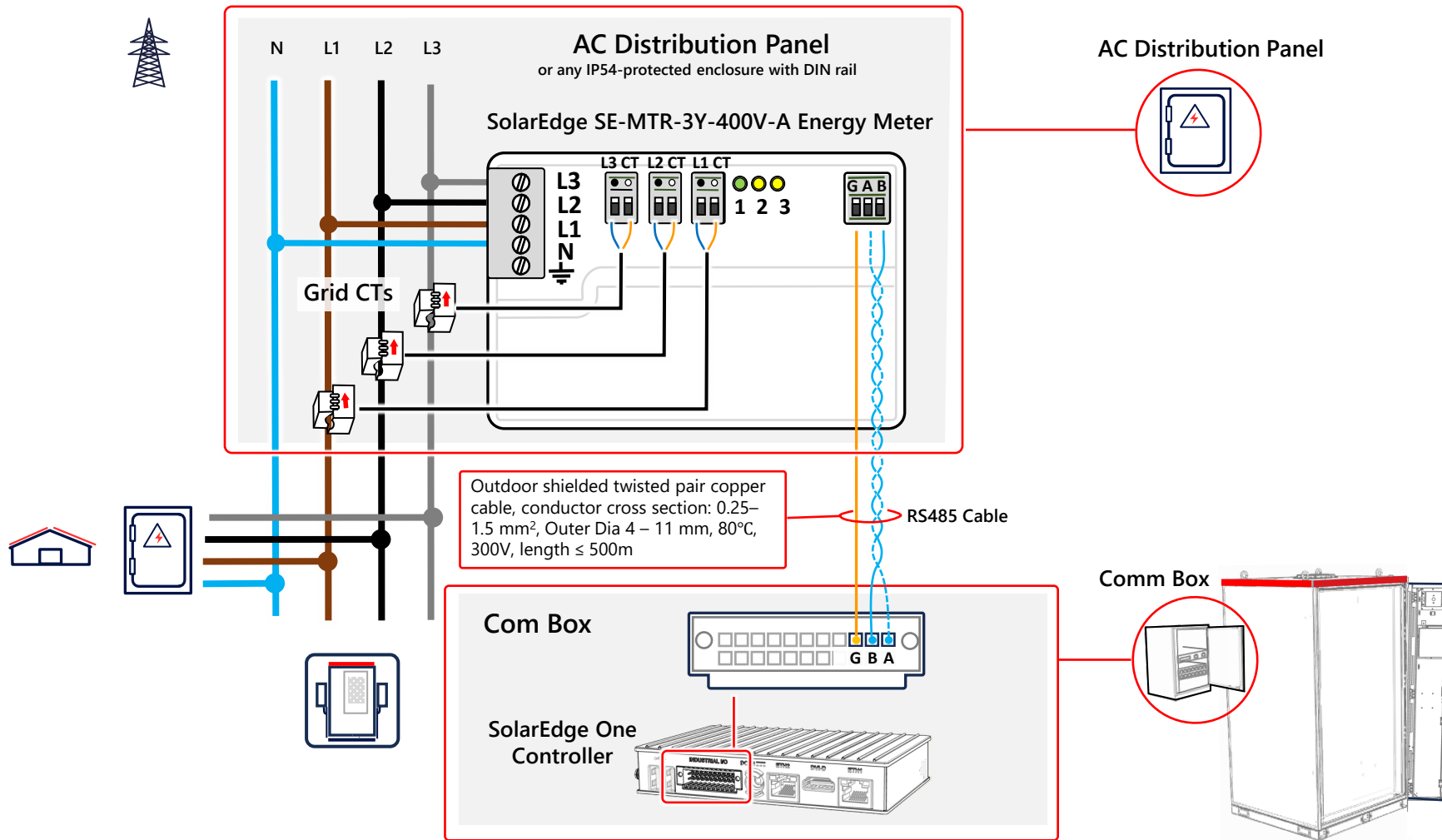

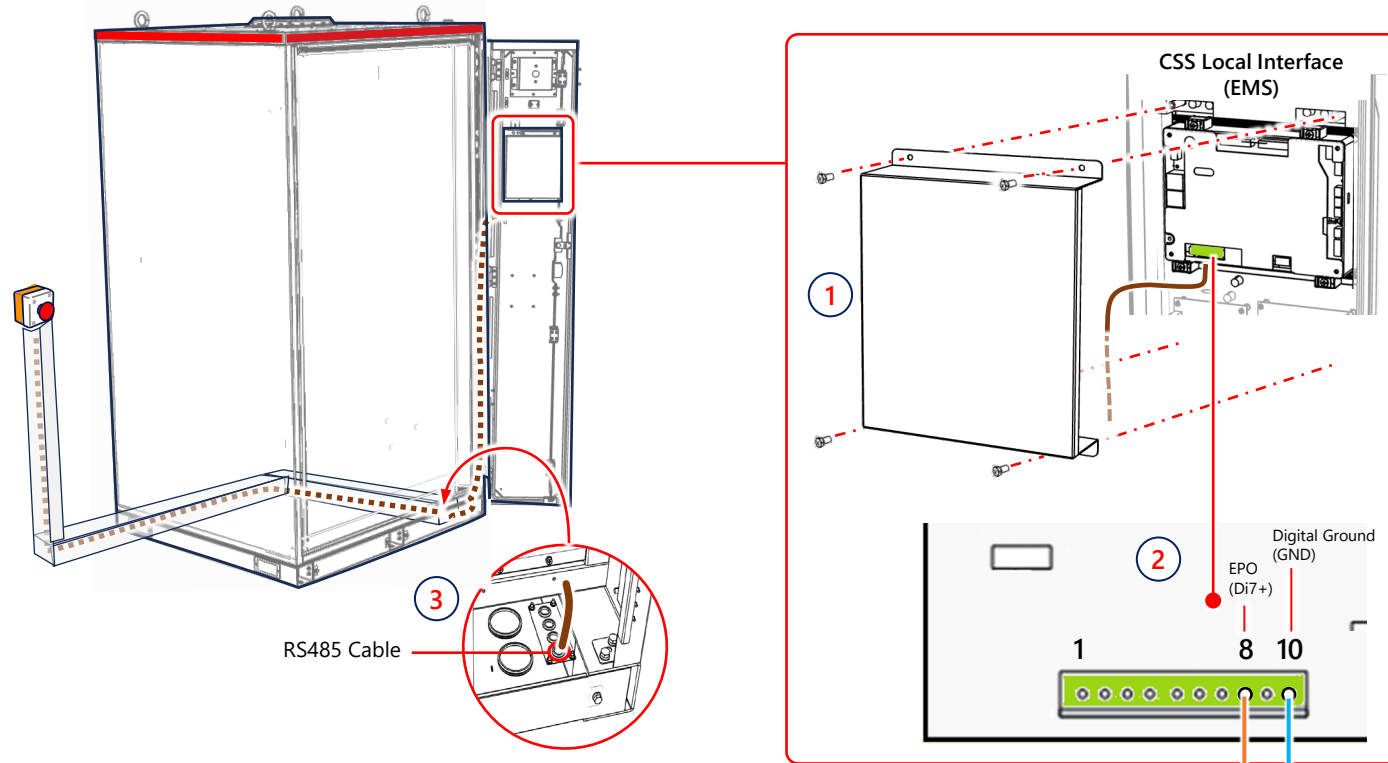

Follow Wiring Procedure

- Connect Remote EPO to the Battery Cabinet Leader using the digital I/O provided in the CSS Local Interface: pin 8 and 10
- Wire all battery cabinet leaders on site with the same method.
- Do not add any additional wiring to 'Follower' batteries.

Remote EPO Requirements

- Use only passive Normally Open (N.O.), EPO push-button
- The EPO push-button of the Leader Inverter trips all Follower Battery Cabinet(s).
- Recovery duration is 1 second

Sealing and Closing Wiring Duct Lid and Panels

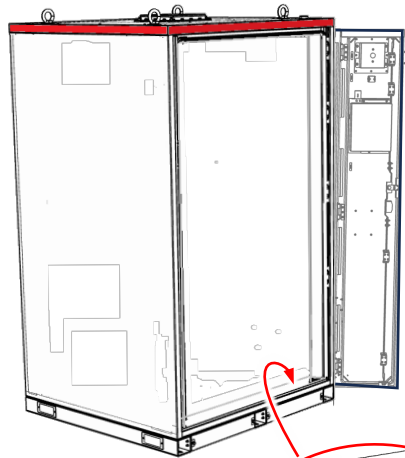

IMPORTANT! Use fire clay sealant to block the cable exit gaps and seal unused wiring holes.

Fire Clay Sealant (H)

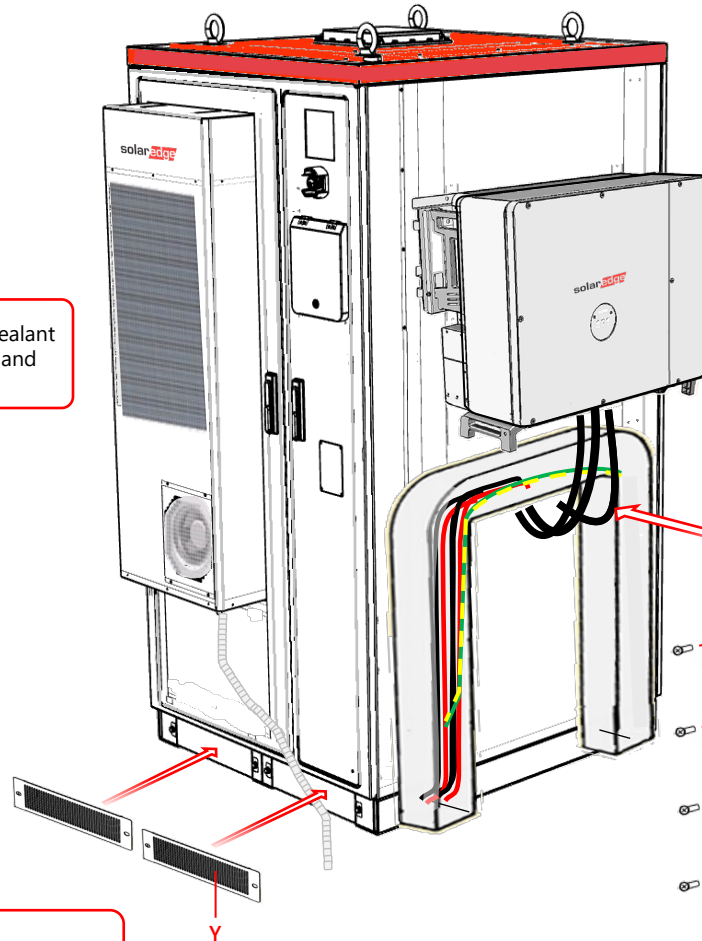
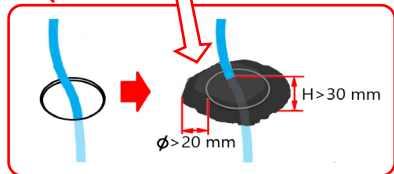
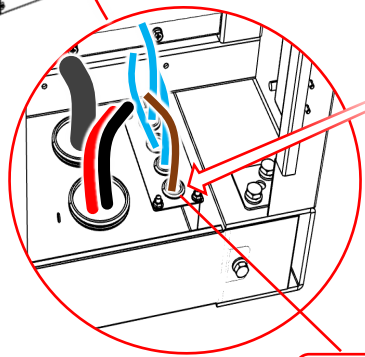

Get parts from: Battery Cabinet Package (Y, G [Duct Cover])

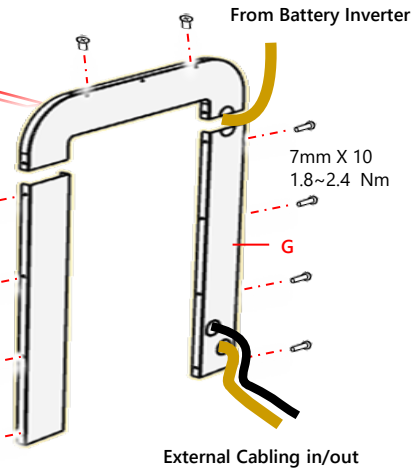



Appendix A

Powering the CSS-OD

Follow the numbered steps to power on the system

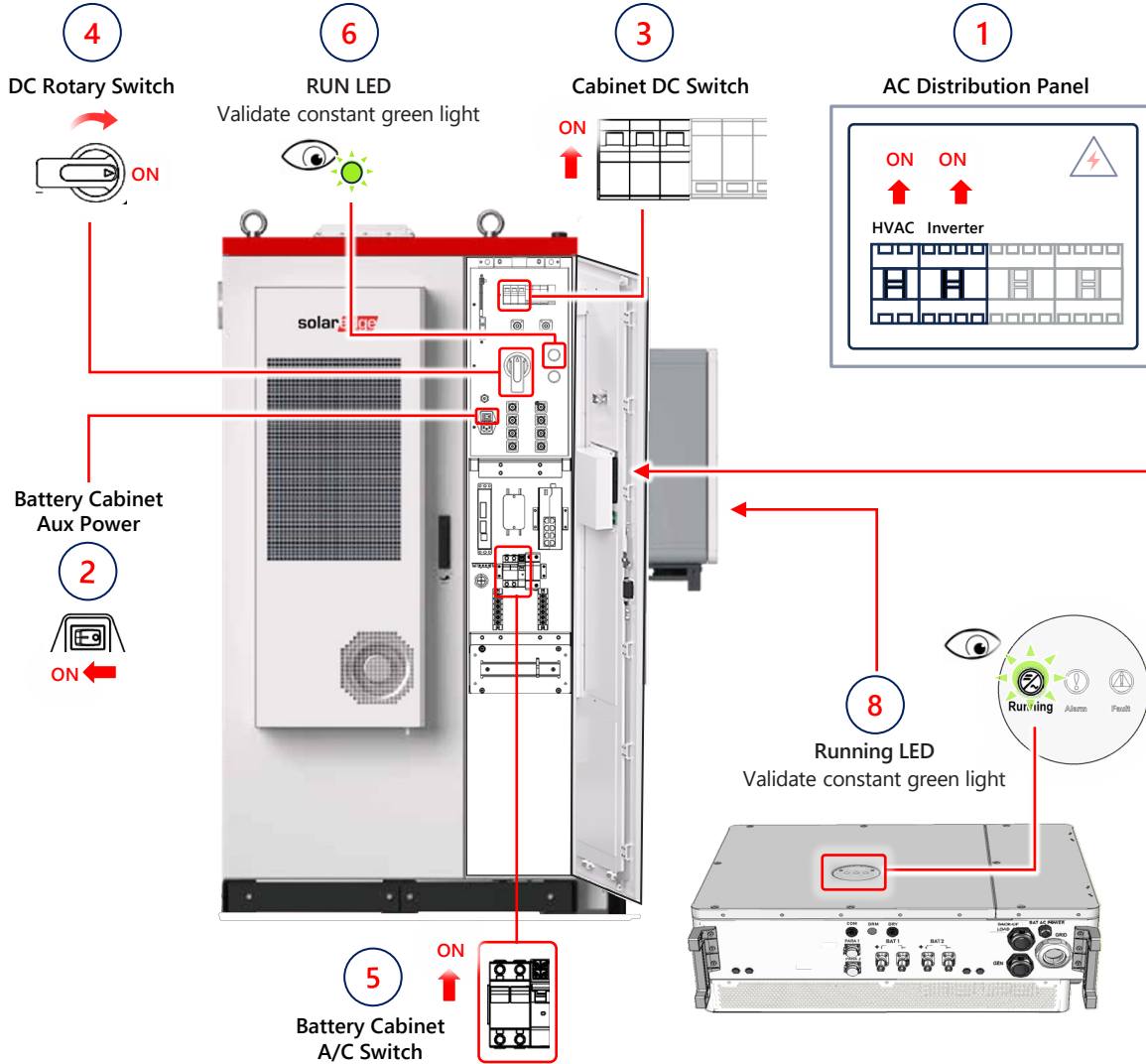

CAUTION! Before powering up the Battery Inverter, it is necessary to verify the connection of all cables and make sure they are correct and tight.

7

EMS Screen

1. Click : Settings → Battery Inverter → Battery Inverter ON/OFF → ON.
2. Enter password: 000000, issue Inverter power on command. The → Battery Inverter ON/OFF button changes from green to gray, and the Running LED light changes from steady red to green.
3. Click Home to check device status, active power, and DC voltage to confirm successful operation.
4. Click the Device tab to check the operating status and voltage of Inverter and battery cabinet to confirm successful operation.

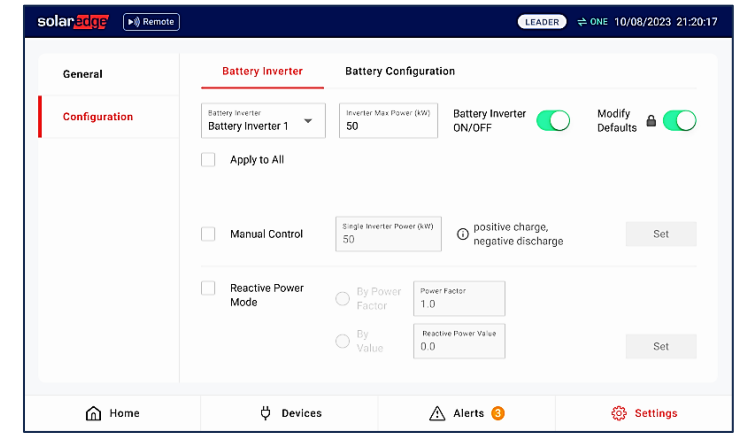

Power Off Sequence

Follow the numbered steps to power off the system

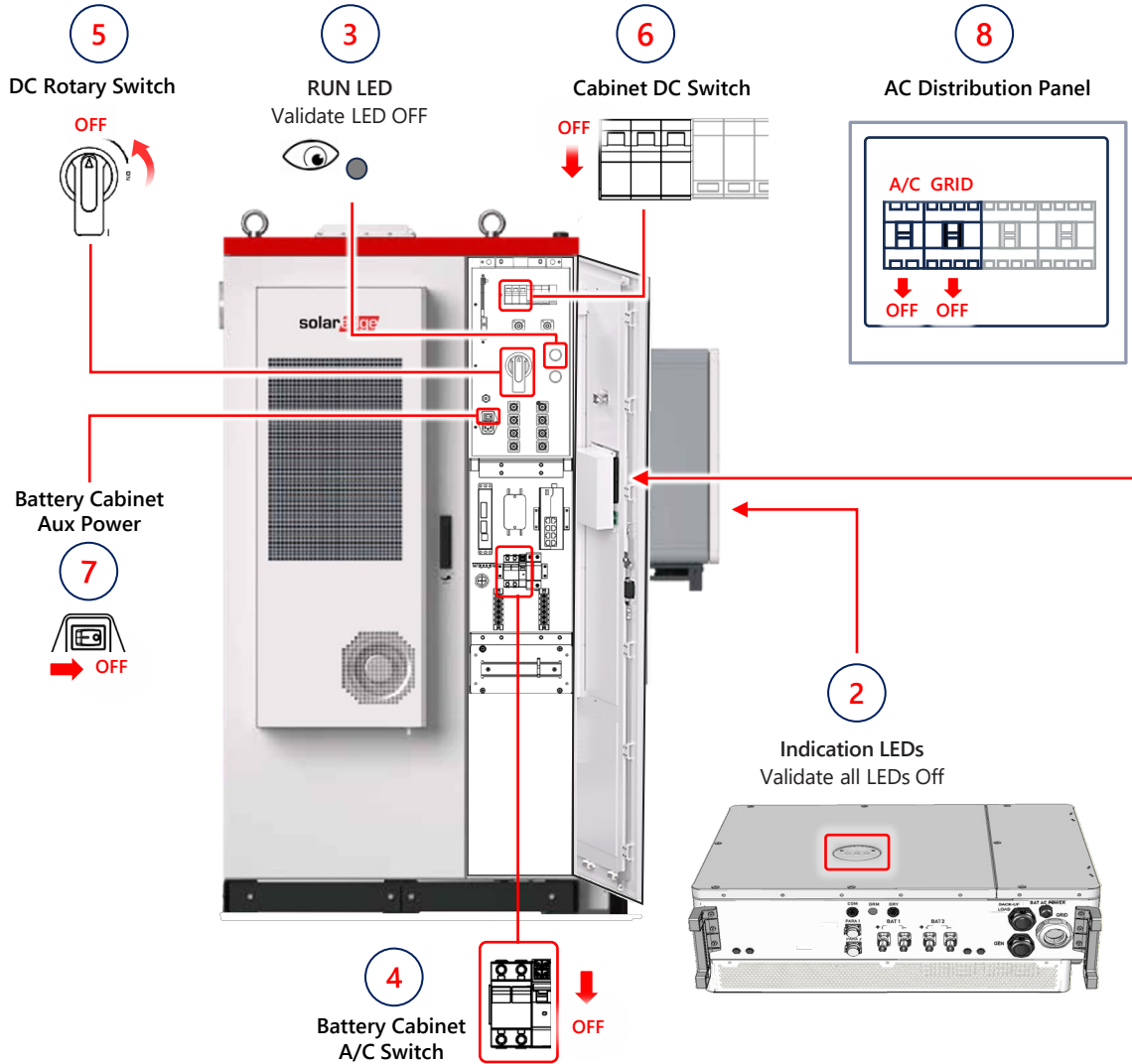

1 EMS Display

1. Click: Settings → Battery Inverter → Battery Inverter ON/OFF → OFF.
2. Enter password: 000000, issue Inverter shutdown command. The shutdown button changes from green to gray, and the Running LED changes from steady green to flashing red.

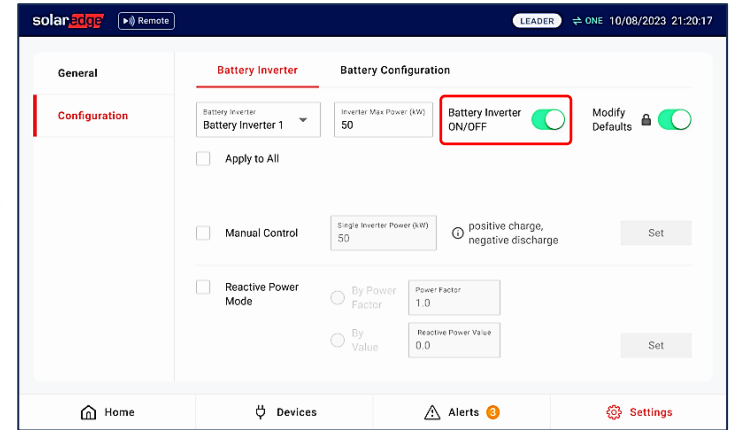



Appendix B

Commissioning

1 When the cabinet boots, it shows a Welcome screen - Tap Let's

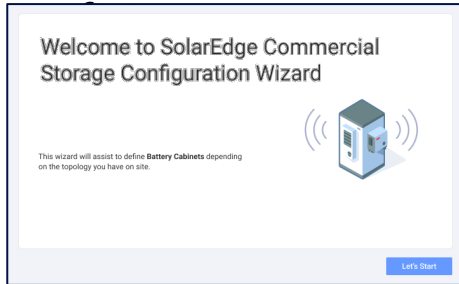

2 Select 107 kWh (CSS-OU-107) and tap Next

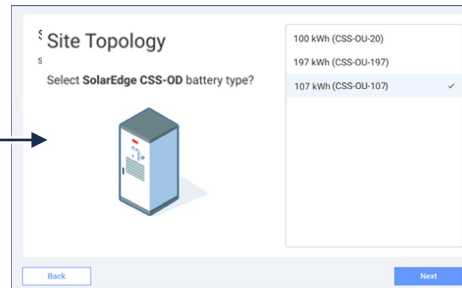

3 View detected Errors and resolve issues after commissioning. Tap Next

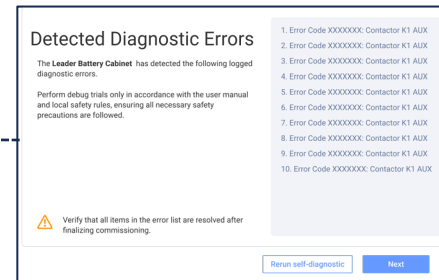

4 Detect or enter all Battery Cabinet S/N and tap Next

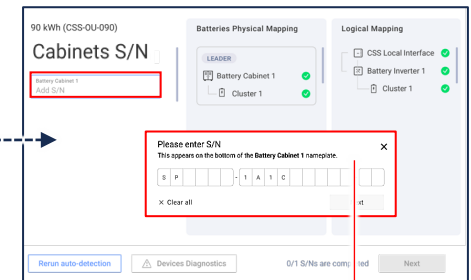

7 Home Screen

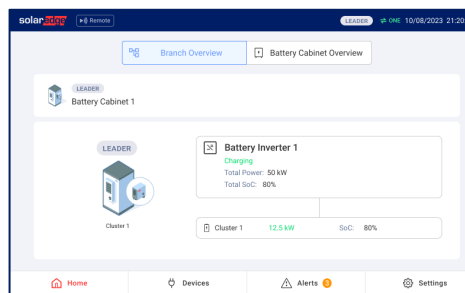

6 Tap Next to display the Home screen

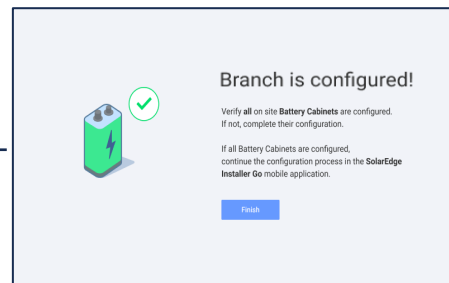

5 Select your country and tap Next

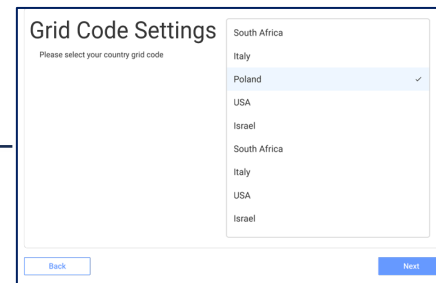

1. Tap Settings for:

- Turning the inverter power ON/OFF
- Setting max power generation limit
- Changing Grid code
- Network Settings
- Firmware version, update and reset (CSS-OD restart)

8 Install SolarEdge Go for SolarEdge ONE Controller for C&I Configuration

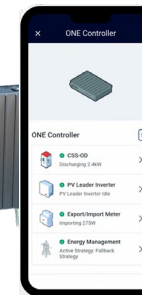

<https://youtu.be/KVCRGSEq8VU>

Setting Communication

IMPORTANT! In some firmware versions, communication is configured by default and does not require modification.

1 Tap Settings on the Home Screen

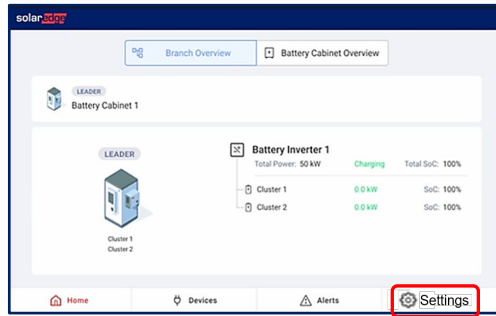

2 Tap General > Network

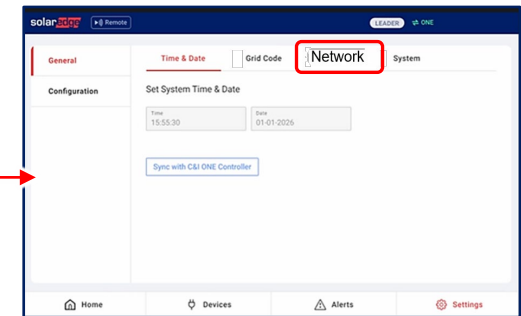

5 Install SolarEdge Go for SolarEdge ONE Controller for C&I Configuration



<https://youtu.be/KVCRGSEq8VU>

4 Tap Accept

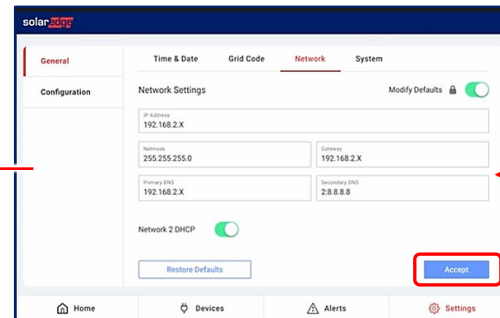

3 Tap Modify Defaults and enter the password > Next

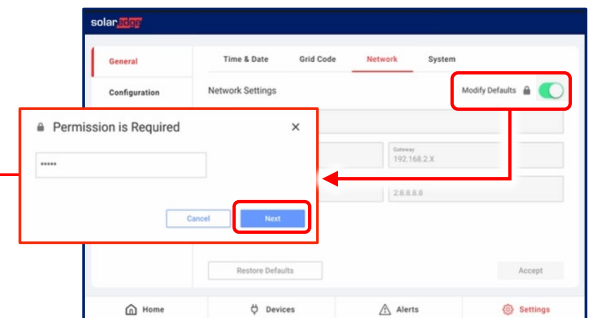



Appendix C

Troubleshooting and Maintenance

Troubleshooting

| Fault Description | Possible Cause | Corrective Action |
|-----------------------------|---|--|
| Grid Overvoltage | Grid voltage above permissible limit | <ul style="list-style-type: none"> • Check Grid Code settings • Check grid voltage with a multimeter. • Contact utility provider if voltage remains high. |
| Grid Undervoltage | Grid voltage below permissible limit | <ul style="list-style-type: none"> • Verify connection at AC terminals. • Check for utility fluctuations or loose wiring. |
| Grid Frequency Error | Frequency outside 50/60 Hz ± 0.5 Hz | <ul style="list-style-type: none"> • Confirm local grid frequency stability. • Wait for automatic reconnection once frequency normalizes. |
| Insulation Resistance Fault | Low insulation resistance detected on DC side | <ul style="list-style-type: none"> • Check for good earth resistance of BT+ and BT- battery terminals is greater than 2 MΩ. • Replace defective module or cable. |
| Ground Fault | Leakage current detected | <ul style="list-style-type: none"> • Inspect for damaged cables or moisture ingress. • Dry the system and re-test insulation. |
| Temperature Overheat | Inverter temperature exceeds safe limit | <ul style="list-style-type: none"> • Ensure ambient temperature is within range. • Clean heat sink and check for blocked airflow. • Verify fan operation (if equipped). |
| Communication Failure | Lost connection with SolarEdge ONE system | <ul style="list-style-type: none"> • Check communication wiring and connectors. • Verify that SolarEdge ONE Controller is powered. • Verify that your site router is powered and connected to the internet. |

Maintenance

NOTE: For CSS-OD routine maintenance guide, refer to: <https://knowledge-center.solaredge.com/sites/kc/files/se-css-od-90-routine-maintenance-guide.pdf>

Battery Inverter LED Indications

| LED Indication(s) | | Description |
|----------------------------------|-------------------------|---|
| All LEDs are Off | Running Alarm Fault | The battery inverter is powered off |
| Steady Green | Running Alarm Fault | Standard operation |
| Flashing Yellow and steady Red | Running Alarm Fault | Self-test |
| Steady Yellow and steady Red | Running Alarm Fault | Standby mode |
| Steady | Running Alarm Fault | Faulty Inverter (Contact support) |
| Flashing Red | Running Alarm Fault | Severity level: Inverter fault (Contact support) |
| Steady Green and flashing Yellow | Running Alarm Fault | Normal operation; state of charge approaching 100% or 0% |



Appendix D

Construction Details

IMPORTANT NOTES!

1. Battery Cabinet must be installed on a reinforced concrete platform base.
2. Dig a trench or reserve a cable entry hole by considering the electrical wiring of the equipment before construction of the foundation.
3. The foundation must be made of non-combustible materials.
4. The bearing capacity of the foundation shall be > 3 t.
5. When designing and manufacturing the embedded steel plates for the battery cabinet, it is necessary to consider that there must be a reliable connection (reinforcement hook) between the embedded steel plate and the concrete base.
6. When molding the concrete pad, it shall protrude below the ground a minimum of 400 mm.
7. To avoid flood damage and safety hazards, the cabinet must be installed on a concrete platform with a minimum height of 300 mm. The Concrete base surface smoothness shall be $\leq 3\text{mm}$.
8. The upper surface tolerance of the foundation shall be $\pm 5\text{mm}$.
9. The concrete pad shall prevent rainwater accumulation on top of it. The foundation construction should meet the drainage requirements for the maximum volume of rainfall in the locality, and the discharged water needs to be treated in accordance with local laws and regulations.
10. The foundation drawing is only for reference and cannot be regarded as the final construction drawing. Operators shall recheck the basic parameters according to the environment, geological conditions, seismic requirements, etc., of the installation site.

Concrete Platform Base

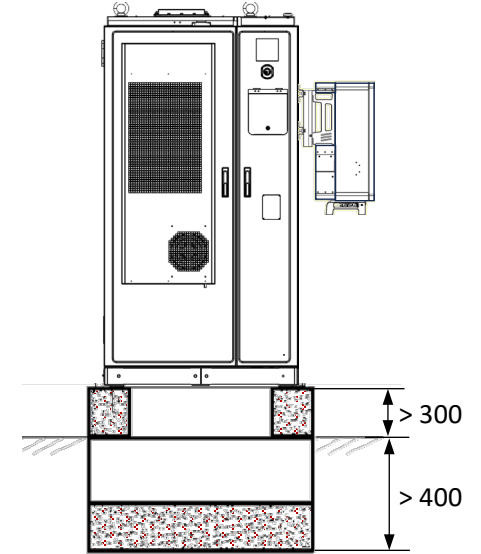
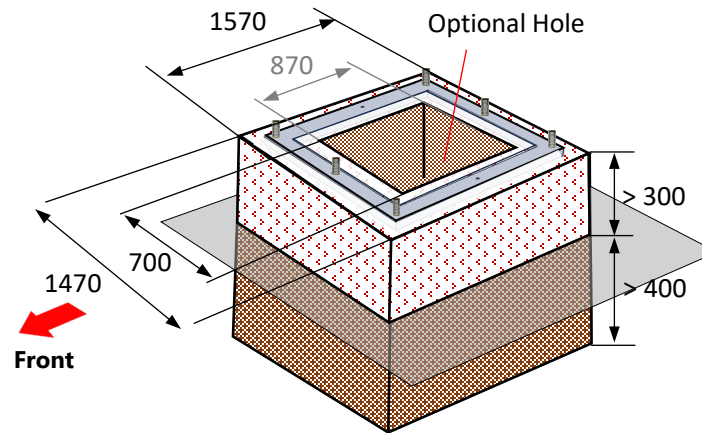

Embedded Steel Plate with Studs

Embedded Steel Plate 100 / 10

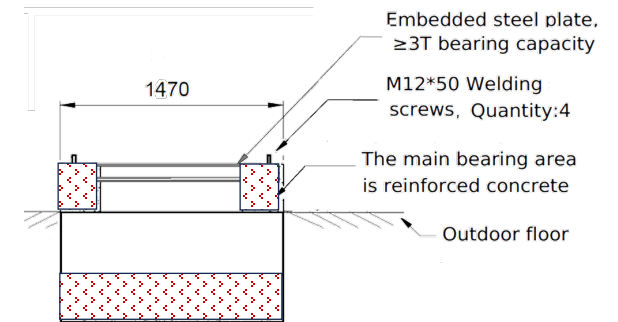
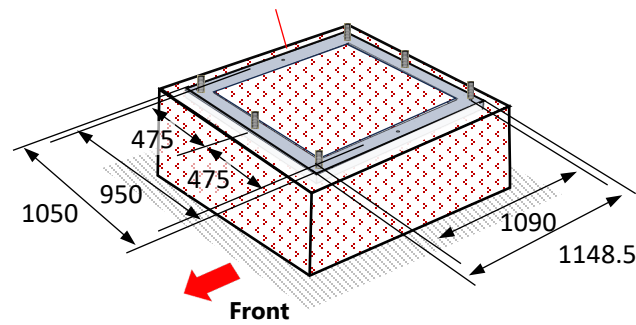

All dimensions are in mm



Support Contact Information

If you have technical problems concerning SolarEdge products, please contact us:

<https://www.solaredge.com/service/support>

Subject to change without notice.

Copyright © SolarEdge Inc.

All rights reserved. April 29, 2026.

SolarEdge Technologies, Ltd. All rights reserved.
SOLAREEDGE, the SolarEdge logo, OPTIMIZED BY SOLAREEDGE
are trademarks or registered trademarks of SolarEdge
Technologies, Inc. All other trademarks mentioned herein
are trademarks of their respective owners.